



Copper Brass Bronze
Design Handbook

Sheet Copper Applications



COPPER DEVELOPMENT ASSOCIATION INC.



INTRODUCTION

Innovation. It is the one constant that architecture has embraced over the centuries. These are pluralistic times for architects, giving rise to a wide diversity of optional design directions. The continuous development of new expressions and solutions however has taken on new aspects.

Some emerging priorities are important to acknowledge. Architects have long sought quality in both design and materials, knowing that the result will be superior performance aesthetically and physically. And, like society in general, designers are aware of such properties as strength—and related weight—and endurance.

It has been shown that quality can lead to reduced maintenance cost and increased product life, viewed on a building life basis. Also, as concerns about energy costs and material availability mount, there are inevitable questions about almost all commodities. This book is about copper. Copper is a time honored friend of architects, inviting the innovation that is their constant forte. Copper is lightweight, strong, formable, and its aesthetic qualities are proven by time. With life cycle costs replacing first cost in architect-client priorities, copper again proves its superiority.

In terms of energy use and availability, published reports show that, in relation to other competitive materials, copper requires less energy to produce and is much more abundant as a resource. In addition,

it is infinitely more recyclable. Documentation of these aspects is available from the Copper Development Association Inc. should further detail be of interest.

This handbook is intended to acquaint design professionals with all of the applications and properties of sheet copper as it applies to buildings, and to invite further innovation. Certainly, every aspect of the use of copper in buildings cannot be included in this book. The Copper Development Association Inc. maintains a staff of strategically located representatives across the country to assist the professional with technical questions or application advice.



COPPER DEVELOPMENT ASSOCIATION INC.
2 Greenwich Office Park, Greenwich, CT 06836

1 Sheet Copper Fundamentals (Pages 4 through 8)

2 Sheet Copper in Design (Pages 10 through 29)

3 Sheet Copper Details (Pages 30 through 45)

4 Sheet Copper Specifications (Pages 46 through 50)

5 Sheet Copper in Depth (Pages 51 through 56)

SECTION 1	
SHEET COPPER FUNDAMENTALS	4
<i>Types of Sheet Copper</i>	4
110 Cold Rolled Copper	4
110 Soft Copper	4
Lead-Coated Copper	4
<i>Sizes in Which Sheet and Strip Copper are Available</i>	4
Thickness or Gauge	4
Width and Length	4
<i>Selection of the Proper Weight of Copper</i>	4
<i>Structural Design of Sheet Copper</i>	4
Preventing Cumulative Stresses	5
Resisting Cumulative Stresses	5
Yielding to Cumulative Stresses	5
<i>Other Shapes</i>	5
<i>Non-Structural Design Considerations</i>	5
Galvanic Corrosion	5
Galvanic Number Column	5
Erosion	6
<i>Surfaces for Laying Copper</i>	6
Copper on Wood	6
Copper on Concrete	6
Copper on Other Materials	6
<i>Copper Fastenings</i>	6
Cleats	8
Nails	8
Screws	8
<i>Copper Seams and Joints</i>	8
Rigid Seams	8
Loose Seams and Joints	8
SECTION 2	
SHEET COPPER IN DESIGN	10
Edward Larrabee Barnes	11
Eero Saarinen & Associates	13
Pietro Belluschi in Association with Rodgers, Taliaferro & Lamb	15
Dolf Schnebli	17
Davis, Brody & Associates	19
Pietro Belluschi in Association with Robinson, Green & Baretta	21
Progressive Design Associates	23
Urbahn, Brayton, and Burrows	25
Geddes, Brecher, Qualls, Cunningham	27
Edward Larrabee Barnes	29

Notice: This Handbook has been prepared for the use of architects and other design professionals. It has been compiled from information supplied by testing, research, manufacturing, standards, and consulting organizations that Copper Development Association Inc. believes to be competent sources for such data. However, recognizing that each system must be designed to meet the particular circumstances, CDA assumes no responsibility or liability of any kind in connection with this Handbook or its use by any person or organization, and makes no representations or warranties of any kind hereby.

SECTION 3			
SHEET COPPER DETAILS	30		
Through-Wall Flashings at Heads, Sills and Water Tables	30		
Spandrel Flashing and Base Course	31		
Flashing at Intersection of Flat Roof with Wall	32		
Coping Covers	33		
Flashing at Intersections of Pitched Roofs and Wall	34		
Chimney Flashing, Vent and Ventilator Flashing and Pitch Pocket	35		
Ridge and Valley Flashing	36		
Change in Roof Slope Flashing	37		
Building Expansion Joint at Roof and Wall with Parapet at Roof Edge and Expansion in One Direction	38		
Building Expansion Joint at Exterior Masonry Walls	39		
Flat Seam Roofing	40		
Standing Seam Roofing	41		
Batten Seam Roofing	42		
Chevron Roofing	43		
Gutters	44		
Gravel Stops and Fascias	45		
SECTION 4			
SHEET COPPER SPECIFICATIONS	46		
<i>General</i>	46		
<i>Scope</i>	46		
<i>Work of Other Sections</i>	46		
<i>Materials</i>	46		
Sheet Copper	46		
Lead Coated Copper	46		
Nails and Fasteners	46		
Solder	46		
Flux	46		
Roofing Felt	46		
Building Paper	46		
Reglets	46		
Sealant	46		
<i>Samples</i>	46		
<i>Shop Drawings</i>	46		
<i>General Requirements</i>	46		
Cleats	46		
Tinning	46		
Soldering	46		
Edge and Drip Strips	46		
Seams	47		
Dissimilar Metals	47		
Reglets	47		
<i>Preparation of Surfaces</i>	47		
<i>Flashing</i>	47		
General	47		
Base Flashing	47		
Cap Flashing	47		
Through-Wall Flashing	47		
Valley Flashing	48		
Stepped Flashing	48		
<i>Building Expansion Joints</i>	48		
Roofs	48		
Exterior Walls	48		
Floors	48		
<i>Flat Seam Roofing</i>	48		
Size	48		
Installation	48		
Soldering	48		
Edge Strips	48		
<i>Standing Seam Roofing</i>	48		
Size	48		
Surface Preparation	48		
Pan Method	48		
Roll Method	48		
Layout	48		
Seam Forming	49		
Ridges and Hips	49		
Valleys	49		
<i>Batten Seam Roofing</i>	49		
Battens	49		
Size	49		
Cross Seams	49		
Layout	49		
Batten Covers	49		
Ridges and Hips	49		
Valleys	49		
Eaves	49		
Gables	49		
<i>Built in Box Gutters</i>	49		
Surface Preparation	49		
Size	49		
Fastenings	49		
Roof Edges	49		
Outer Edges	49		
Expansion Joints	50		
Outlet Tubes to Conductors	50		
Strainers	50		
<i>Hung Molded Gutters</i>	50		
Size	50		
Outer Edges	50		
Expansion Joints	50		
Braces	50		
Hangers	50		
Outlet Tubes	50		
Strainers	50		
<i>Leaders</i>	50		
Size	50		
Hangers	50		
Elbows	50		
Leader Heads	50		
<i>Gravel Stops and Fascias</i>	50		
Size	50		
Edge Strip	50		
Fastening	50		
Flashing	50		
<i>Pitch Pockets</i>	50		
<i>Copings</i>	50		
<i>Cleaning</i>	50		
<i>Coloring of Copper</i>	50		
<i>Guarantee</i>	50		
SECTION 5			
SHEET COPPER IN DEPTH	51		
<i>Sealants</i>	51		
Performance	51		
Surface Preparation	51		
<i>Corrosion Resistance and Staining</i>	51		
Line Corrosion	51		
Galvanic Corrosion	52		
Staining	52		
<i>Lead-Coated Copper</i>	52		
Coating Weights	52		
Gauge Selection	52		
Soldering	52		
<i>Mechanized Copper Roofing</i>	53		
Shop Fabrication	53		
History	53		
Current Equipment	53		
Advantages	53		
<i>Natural Weathering and Chemical Coloring</i>	54		
Oiling and Waxing	55		
Chemical Coloring	55		
Clear Coatings	56		

SHEET COPPER FUNDAMENTALS

4

SHEET COPPER FUNDAMENTALS

Copper. It resists attack by air and moisture. It is lightweight, easy to work and join, attractive, and extremely durable. These properties have made it the architect's natural choice for centuries, offering wide design options for roofs, fascias, gutters, scuppers, downspouts, and all types of flashing. What follows is a collection of material to aid the design professional in the use of sheet copper.

TYPES OF SHEET COPPER

Currently, there are three types of 110 sheet copper in use: cold rolled copper, soft copper, and lead coated copper. Cold rolled copper has always been available in most standard gauges, but has recently been developed in an additional high-strength 12 oz. sheet, "Tough 12."

110 Cold rolled copper

Cold rolled copper is by far the most frequently used. It is less malleable than soft copper, but is far stronger. Unless otherwise noted, all references in this book are to cold rolled copper. ASTM "Standard Designations for Copper and Copper Alloys" contains the definition of 110 cold rolled temper copper. The newer "Tough 12" copper sheet enables the designer to reduce the cost and weight of copper specified for certain applications, without impairing performance.

110 soft copper

Soft copper is used only for applications where extreme malleability is required, such as for intricate ornamental copper work. As the applications of 110 soft temper sheet copper in building construction are extremely limited, it is recommended that only 110 cold rolled temper copper be used throughout so as to preclude the accidental misuse of soft temper copper.

lead-coated copper

Lead-coated copper has the gray color of lead. With respect to workability, ease of joining, and strength, it is similar to 110 cold rolled copper.

SIZES IN WHICH SHEET AND STRIP COPPER ARE AVAILABLE**thickness or gauge**

Thickness or gauge of copper is expressed in the building industry in terms of "ounces per square foot." Therefore, 16 oz. copper is copper of a thickness that weighs 16 oz. per square foot. The table below, on the left, lists the weights of copper most generally used in the building industry.

width and length

Copper is designated "sheet copper" or "strip copper" depending on its width. Sheet copper is over 24" wide. Strip copper is 24" wide or under. The sizes are governed as indicated in the table below, on the right.

SELECTION OF THE PROPER WEIGHT OF COPPER

The weight of copper to be used in any particular application is influenced by structural, physical, and chemical properties, such as shape of section, types of joints and seams, thermal movement anticipated, types of fastenings, and degree of erosion and corrosion expected.

The structural requirements may be calculated by employing the same structural design formulas used in calculating for steel, wood, or any other material of uniform strength, using the unit strengths and sizes of copper listed under "Physical Properties of 110 Cold Rolled Copper." For certain shapes, the Critical Load Table included under "Structural Design of Sheet Copper" will be of value. Physical and chemical properties are listed and discussed elsewhere in this section.

A list of copper applications and recommended weights is shown at the right.

STRUCTURAL DESIGN OF SHEET COPPER

Sheet copper, when formed to a specific shape, such as a gutter, coping, fascia or gravel stop, and installed on a building, will behave as a structural column when subjected to conditions causing expansion. The columnar rigidity or strength of a section is its ability to transfer movement caused by this expansion (most commonly

Thickness or gauge

weight per sq. ft.		thickness (inches)		nearest gauge no. (B&S)	nearest fractions (inches)
ounces	pounds	nominal	minimum		
32	2	.0431	.0405	17	
24	1½	.0323	.0295	20	1/32
20	1¼	.0270	.0245	21	
16	1	.0216	.0190	23	
12	¾	.0162	.0143	26	1/64
10	⅝	.0135	.0115	27	
8	½	.0108	.0090	29	

Width and length

weight per sq. ft. in ounces	width in inches	length in inches
sheet copper		
12	30, 36	96, 120
16	30, 36	96, 120
20	30, 36	96, 120
24	30, 36	96, 120
32	30, 36	96, 120
strip copper		
16	10, 12, 14, 15, 16, 18, 20, 24	96, 120
20	20, 24	96, 120
24	20, 24	96, 120
32	20, 24	96, 120
roll copper (soft temper only)		length in feet
16	6, 7, 8, 10, 12, 14, 16, 18, 20, 24	50 to 100 feet

thermal) to a predetermined point of release, such as an expansion joint, without exceeding the buckling yield point of the copper.

preventing cumulative stresses

Copper will expand approximately 1/8" in 10'-0" over a 100°F change in temperature. If the copper can be restrained frequently enough, no large expansion will be created at any one point and no buckling will occur. In such applications as gravel stops, base flashings at built-up roofs, flashings around windows and

doors, and some eave strips, where movement is particularly undesirable and the fastenings will be covered by other materials, frequent nailing (3" maximum on center) is recommended.

In most applications, however, it is impractical or undesirable to restrain a copper section that frequently. In the interest of watertightness, puncturing of copper should be kept to a minimum. And to minimize metal fatigue, it is better, where possible, to let the copper move than to restrain it.

resisting cumulative stresses

Compressive strength in sheet copper is the product of two factors: the thickness of the copper and the shape of the section designed. These two factors working together create "columnar strength" which resists accumulated compressive stresses. A section which will resist compressive stress will resist at least an equivalent amount of tensile stress. Therefore, the section is designed to resist compression.

A section formed in a given thickness of copper will resist stresses for a certain length of "column." Beyond this point the designer must introduce an expansion joint or the section will buckle.

yielding to cumulative stresses

Once an expansion joint is introduced, the section no longer has to resist all the stresses which would be caused by thermal expansion along its whole length. It now need only keep its shape and resist the friction between itself and its fastenings and the materials to which it is adjacent. For purposes of determining the position of expansion joints, however, the

section is analyzed as a column.

The "Critical Load Table" on page 7 has been created for use in determining the allowable column length (or distance between a fixed point and an expansion joint) for any "U"-shaped section. This is the section most frequently used for such applications as gutters, gutter linings, fascias, and copper pans in standing seam and batten seam roofs, which owe their strength to the flanges forming the seams.

OTHER SHAPES

Copper may be bent in many ways for added strength. It is not feasible to present tables here that indicate the strength of all imaginable copper sections. However, the table on page 6 gives representative strengths achieved by a few of the most commonly employed simple shapes.

NON-STRUCTURAL DESIGN CONSIDERATIONS galvanic corrosion

When dissimilar metals are in contact with one another in the presence of an electrolyte, galvanic action occurs, resulting in the deterioration of the metal with the lower galvanic number (see scale p. 6). The electrolyte may be rain water running from one surface to another, or moisture from the air containing just enough acid to cause it to act as an electrolyte.

galvanic number column.

Since copper has the highest number in the galvanic scale shown, it is evident that it will not be harmed by contact with other metals. Copper may cause considerable deterioration in other materials, however, if it is not insulated from them. For further

Application	Weight (in oz.)
building expansion joints	20
cant strips	16
chimneys	12, 16
edge strips	16 to 32*
flashings:	
apron	12
base, narrow	16
base, wide	20
caps, coping covers	12, 16
cavity wall	10, 12
window and door heads	10, 12
window and door jambs	10, 12
window and door sills	16
gable ends	20
hips	12, 16, 20
hips, saddle	16
masonry veneer, concealed	10, 12
ridges	20
through-wall, concealed	10, 12
through-wall, exposed	16
valleys, closed slate or tile	24
valleys, closed wood	16
valleys, open slate or tile	24
valleys, open wood	16
vents and ventilators	12, 16
gravel stops	12, 16, 20
gutters, built-in box	16 to 32**
gutters, hung half-round	16
gutters, hung molded	20
leaders, leader heads,	
leader straps	16
louvre, frame cover	16
louvre slats	20
outlets, gutter	16
pitch pockets	12, 16, 20
roofing, batten seam,	
up to 20" pans	12, 16
roofing, batten seam,	
over 20" to 24" pans	20
roofing, batten cover, locks,	
strips, and valleys	16
roofing, flat seam,	
sheets and cleats	20
roofing, standing seam—	
16¾" pan width	12, 16
roofing, standing seam—	
20" pan width	20
scuppers	20
siding, standing or flat seam	16

* See specification section for recommended weights.

** See "Resisting Cumulative Stresses".

Physical properties of 110 cold rolled copper

general and thermal properties

specific gravity	8.89 — 8.94
density (weight)	0.322 lb. per cu. in. at 68°F.
thermal conductivity	226 Btu./sq. ft./ft./hr. per °F. at 68°F.
coefficient of thermal expansion	0.0000098 per °F. from 68°F. to 572°F.

mechanical properties (The following figures represent typical values)

modulus of elasticity (tension)	17,000,000 p.s.i.
tensile strength	36,000 p.s.i.
yield strength (0.5% of extension under load)	28,000 p.s.i.
elongation in 2"	30%
shear strength	25,000 p.s.i.
hardness—Rockwell (F Scale)	60 (minimum)
Rockwell (T Scale)	25 (minimum)

discussion of corrosion precautions see section five of this handbook.

Galvanic scale including most commonly used building materials

- | | |
|-------------|-----------|
| 1. aluminum | 5. tin |
| 2. zinc | 6. lead |
| 3. steel | 7. copper |
| 4. iron | |

erosion

It is advisable to avoid creating a condition where concentrated amounts of water hit a copper roof, such as where rain water drains from one roof to another. This action causes erosion of copper. Gutters and downspouts should be provided to deflect and break the fall of water from the upper roof so that it flows evenly down the roof below.

SURFACES FOR LAYING COPPER

Copper should be laid on a substrate which is smooth and dry and has settled permanently into position. The surface must be nailable or contain nailable inserts and the material adjacent to the copper must not contain elements corrosive to copper.

A layer of asphalt-impregnated roofing felt covered by a layer of smooth building paper should be laid over surfaces intended to receive copper roofs, valleys, and gutter linings.

The roofing felt helps to even out abrasive surfaces and acts as a moisture barrier to protect the copper from condensation accumulating on its under side.

The building paper prevents bonding of the copper to the roofing felt, which tends to bleed asphalt in hot weather. This, in

turn, adheres to the copper and hinders its movement.

For specifications of roofing felt and building paper, see specifications sub-section 4f and 4g on p. 46.

For specifications for preparing surfaces and laying of roofing felt and building paper, see specifications sub-section 8 on p. 47.

Special factors must be considered with respect to each substrate surface. These factors are discussed below.

copper on wood

Wood intended as a substrate for copper should be kiln-dried and smooth. It should be laid with all joints true and even and with all nailheads firmly set. It should be allowed to weather for a few days (protected from rain) to allow it to conform to the atmosphere in temperature and moisture content, to expand and contract and to settle into final position. Thus laid and thus weathered, the wood provides a smooth, stable surface on which the copper is applied.

In recent years, the use of fire retardant treated plywood and dimensional lumber has proliferated. Most fire retardant treatments employ combinations of chemical salts in solution which are pressure impregnated into the wood. Several of the salts are highly corrosive to all metals including copper. Active corrosion can, and does take place when these salts are leached from the wood by moisture which saturates the wood's surface. Such moisture can stem from condensation, under high humidity conditions, wetting by rain and snow during construction or leaks which develop in service. The resulting chemical attack takes the char-

acteristic form of pitting corrosion of the copper, most frequently at the low points of roofing or flashing installations where the moisture collects and tends to concentrate as a result of evaporation.

The architect should specify fire retardant treatments for wood which utilize chemicals known to be non-corrosive to metals. Where the use of corrosive salts cannot be avoided, the architect should detail the construction in order to minimize the direct contact between the treated wood surfaces and copper roofing or flashing elements. Provision of well ventilated concealed spaces will help to minimize the potential for problems, as will careful detailing of gutters, flashings, and roof terminations to avoid water backup with attendant infiltration to the building interior.

copper on concrete

Concrete intended as a substrate for copper should be made smooth by a wash of neat cement or by heavy coats of asphalt paint. If the concrete is not nailable, nailable inserts must be set into the concrete.

copper on other materials

Surfaces such as terra cotta, stone, brick, stucco, and a great number of roof-sheathing materials are often employed as a substrate for copper. Care should be taken in every case to insure a smooth, dry, nailable laying surface.

COPPER FASTENINGS

Copper is fastened to a substrate by one of three methods: cleating, nailing, or screwing.

Cleats are most frequently used, because they permit movement and

Effect of shape and weight on strength of 110 cold rolled copper

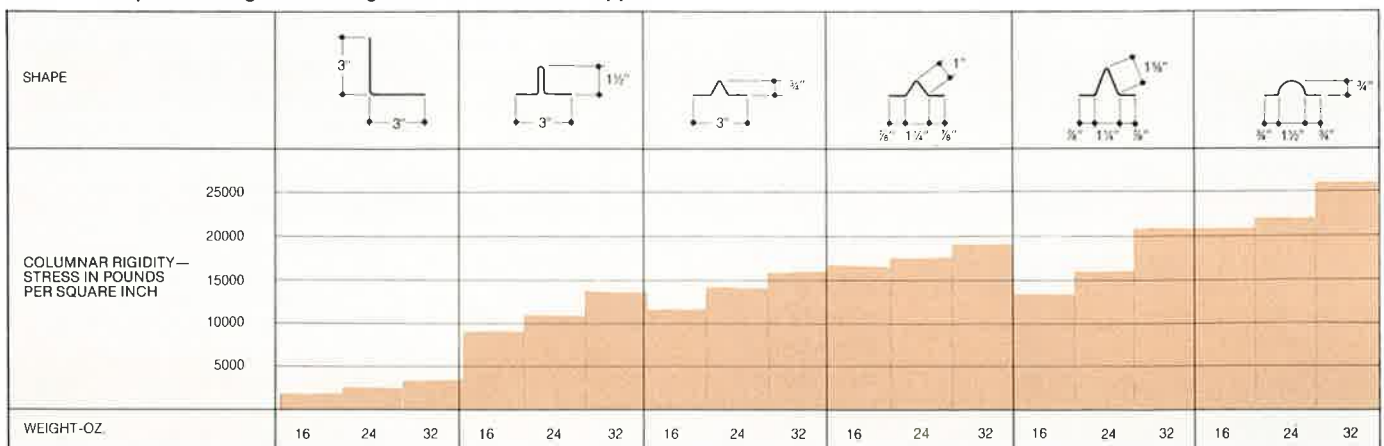

Critical load table

DETERMINATION OF GAUGE AND EXPANSION JOINT LOCATION FOR VARIOUS SIZES AND SHAPES OF COPPER "U" SECTIONS

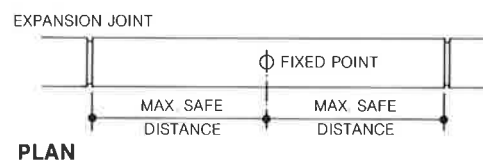
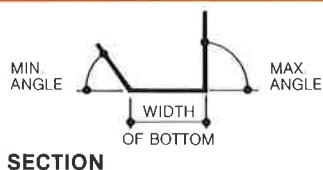

WEIGHT of Cold Rolled Copper in Ounces	Width of Gutter Bottom in Inches	MAXIMUM DISTANCE BETWEEN FIXED POINT AND EXPANSION JOINT IN FEET															
		ANGLE OF GUTTER SIDES															
		90° Max.	90° Max.	90° Max.	90° Max.	90° Max.	60° Max.	60° Max.	60° Max.	60° Max.	45° Max.	45° Max.	45° Max.	35° Max.	35° Max.	25° Max.	
25° Min.	35° Min.	45° Min.	60° Min.	90° Min.	25° Min.	35° Min.	45° Min.	60° Min.	25° Min.	35° Min.	45° Min.	25° Min.	35° Min.	25° Min.			
16	4	19'-6"	20'-6"	21'-6"	23'-0"	26'-0"	17'-0"	18'-0"	19'-6"	20'-6"	16'-6"	17'-0"	18'-0"	13'-6"	15'-0"	12'-0"	
	6	16'-6"	17'-6"	18'-6"	19'-6"	21'-6"	14'-0"	15'-0"	16'-6"	17'-6"	13'-0"	14'-0"	15'-0"	11'-6"	12'-6"	10'-6"	
	8	14'-0"	15'-0"	16'-0"	17'-6"	19'-0"	12'-0"	13'-0"	14'-0"	15'-0"	10'-6"	12'-0"	13'-0"	9'-6"	10'-0"	8'-6"	
	10	12'-0"	13'-0"	14'-0"	15'-0"	16'-6"	10'-0"	11'-0"	12'-0"	13'-0"	9'-0"	10'-0"	11'-0"	7'-6"	8'-0"	6'-0"	
	12	10'-6"	11'-6"	12'-0"	13'-6"	14'-6"	9'-0"	9'-6"	10'-6"	11'-6"	8'-0"	9'-0"	10'-0"	6'-0"	7'-0"	5'-0"	
	14	9'-6"	10'-0"	11'-0"	12'-0"	13'-0"	7'-6"	8'-6"	9'-6"	10'-6"	6'-6"	7'-6"	8'-6"				
	16	8'-6"	9'-0"	10'-0"	11'-0"	12'-0"	7'-0"	7'-6"	8'-6"	9'-0"	6'-0"	7'-0"	7'-6"				
20	4	25'-0"	27'-0"	28'-0"	30'-6"	34'-0"	22'-0"	24'-0"	25'-0"	27'-0"	20'-0"	22'-0"	24'-0"	17'-6"	19'-6"	16'-0"	
	6	21'-6"	23'-0"	24'-0"	26'-0"	29'-0"	18'-6"	20'-0"	21'-6"	23'-0"	17'-0"	18'-6"	20'-0"	15'-6"	17'-6"	14'-0"	
	8	18'-0"	19'-6"	20'-6"	22'-0"	24'-6"	15'-6"	17'-0"	18'-0"	19'-6"	14'-0"	15'-6"	17'-0"	13'-0"	14'-6"	11'-6"	
	10	15'-6"	17'-0"	18'-0"	19'-6"	21'-6"	13'-6"	15'-0"	15'-6"	17'-0"	12'-6"	13'-6"	15'-0"	11'-0"	12'-6"	10'-0"	
	12	14'-0"	15'-0"	16'-6"	17'-6"	19'-6"	12'-0"	13'-6"	14'-0"	15'-0"	11'-0"	12'-0"	13'-6"	10'-0"	11'-0"	8'-6"	
	14	12'-6"	13'-6"	14'-6"	15'-6"	17'-6"	11'-0"	12'-0"	12'-6"	13'-6"	9'-6"	11'-0"	12'-0"	9'-0"	10'-0"	8'-0"	
	16	11'-6"	12'-6"	13'-6"	14'-6"	16'-0"	10'-0"	11'-0"	11'-6"	12'-6"	9'-0"	10'-0"	11'-0"	8'-0"	9'-0"	7'-0"	
	18	10'-6"	11'-6"	12'-6"	13'-6"	14'-6"	9'-0"	10'-0"	10'-6"	11'-6"	8'-0"	9'-0"	10'-0"				
	20	10'-0"	10'-6"	11'-6"	12'-6"	14'-0"	8'-6"	9'-0"	10'-0"	10'-6"	7'-6"	8'-6"	9'-0"				
24	4	32'-0"	34'-0"	36'-0"	38'-6"	41'-6"	28'-0"	30'-0"	32'-0"	34'-0"	25'-5"	28'-0"	30'-0"	23'-6"	26'-0"	21'-0"	
	6	27'-0"	29'-0"	30'-6"	33'-0"	36'-0"	24'-0"	26'-0"	27'-0"	29'-0"	22'-0"	24'-0"	26'-0"	20'-0"	22'-0"	18'-6"	
	8	23'-6"	25'-0"	26'-0"	28'-0"	31'-0"	20'-0"	22'-0"	23'-6"	25'-0"	18'-6"	20'-0"	22'-0"	17'-0"	19'-0"	15'-6"	
	10	20'-6"	22'-0"	23'-0"	25'-0"	27'-0"	18'-0"	19'-6"	20'-6"	22'-0"	16'-6"	18'-0"	19'-6"	15'-0"	16'-6"	13'-6"	
	12	18'-6"	20'-0"	21'-0"	22'-6"	24'-6"	16'-0"	17'-6"	18'-6"	20'-0"	14'-6"	16'-0"	17'-6"	13'-6"	15'-0"	12'-0"	
	14	17'-0"	18'-6"	19'-6"	20'-6"	22'-6"	14'-6"	16'-0"	17'-0"	18'-6"	13'-6"	14'-6"	16'-0"	12'-0"	13'-6"	11'-0"	
	16	15'-6"	16'-6"	17'-6"	19'-0"	21'-0"	13'-6"	14'-6"	15'-6"	17'-0"	12'-6"	13'-6"	14'-6"	11'-0"	12'-6"	10'-0"	
	18	14'-6"	15'-6"	16'-6"	18'-0"	19'-6"	12'-6"	13'-6"	14'-6"	15'-6"	11'-6"	12'-6"	13'-6"	10'-6"	11'-6"	9'-6"	
	20	13'-6"	14'-6"	15'-6"	16'-6"	18'-0"	11'-6"	12'-6"	13'-6"	14'-6"	10'-6"	11'-6"	12'-6"	10'-0"	10'-6"	8'-6"	
	22	12'-6"	13'-6"	14'-6"	15'-6"	17'-0"	11'-0"	12'-0"	12'-6"	13'-6"	10'-0"	11'-0"	12'-0"				
	24	12'-0"	13'-0"	14'-0"	15'-0"	16'-6"	10'-6"	11'-6"	12'-0"	13'-0"	9'-6"	10'-6"	11'-6"				
32	6	46'-0"	48'-6"	51'-0"	54'-6"	59'-6"	40'-6"	43'-0"	46'-0"	48'-6"	37'-0"	40'-6"	43'-0"	36'-0"	39'-6"	33'-6"	
	8	41'-0"	44'-0"	46'-0"	49'-0"	53'-6"	36'-6"	39'-0"	41'-0"	44'-0"	33'-6"	36'-6"	39'-0"	31'-0"	34'-0"	28'-6"	
	10	36'-6"	39'-0"	40'-6"	43'-6"	47'-6"	32'-6"	34'-6"	36'-6"	39'-0"	30'-0"	32'-6"	34'-6"	27'-6"	30'-0"	25'-0"	
	12	33'-6"	35'-6"	37'-6"	39'-6"	43'-0"	29'-6"	31'-6"	33'-6"	35'-6"	27'-0"	29'-6"	31'-6"	25'-6"	27'-0"	23'-0"	
	14	30'-6"	32'-6"	34'-6"	36'-6"	40'-0"	27'-0"	29'-0"	30'-6"	32'-6"	25'-0"	27'-0"	29'-0"	23'-0"	25'-0"	21'-0"	
	16	28'-6"	30'-6"	32'-0"	34'-0"	37'-0"	25'-0"	27'-0"	28'-6"	30'-6"	23'-0"	25'-0"	27'-0"	21'-0"	23'-0"	19'-6"	
	18	27'-0"	28'-6"	30'-0"	32'-0"	35'-0"	23'-6"	25'-6"	27'-0"	28'-6"	21'-6"	23'-6"	25'-6"	20'-0"	22'-0"	18'-0"	
	20	25'-6"	27'-0"	28'-0"	30'-0"	33'-0"	22'-0"	24'-0"	25'-6"	27'-0"	20'-6"	22'-0"	23'-6"	19'-0"	20'-6"	17'-6"	
	22	24'-0"	25'-6"	27'-0"	28'-6"	31'-6"	21'-0"	22'-6"	24'-0"	25'-6"	19'-6"	21'-0"	22'-6"	18'-0"	19'-6"	16'-6"	
	24	23'-0"	24'-6"	25'-6"	27'-6"	30'-0"	20'-0"	21'-6"	23'-0"	24'-6"	18'-6"	20'-0"	21'-6"	17'-0"	18'-6"	15'-6"	
	26	22'-0"	23'-6"	24'-6"	26'-0"	28'-6"	19'-0"	20'-6"	22'-0"	23'-6"	17'-6"	19'-0"	20'-6"	16'-6"	18'-0"	15'-0"	
28	21'-0"	22'-6"	23'-6"	25'-0"	27'-6"	18'-6"	20'-0"	21'-0"	22'-6"	17'-0"	18'-6"	20'-0"	16'-0"	17'-6"	14'-6"		

thereby minimize buckling.

Nailing is more practical in some instances, such as base flashing at built-up roofing, gravel stops, and eave strips, but only if applied as described below under "Nails."

Screws are used where the copper must be held rigidly in place, as at a ridge roll subject to the severe vibrations caused by wind, or where the copper is secured to a masonry surface hard enough to require the use of expansion shields.

All fastenings should be of copper or copper alloy, except for washers and expansion shields, which are of lead, bronze, rubber or plastic.

cleats

Cleats are generally made of 16 oz. copper at least 2" wide. However, cleats need be no heavier than the material being secured. Each cleat is fastened with two copper or copper alloy nails and the end is folded back over the nails as illustrated below.

Cleats should be spaced no more than 12" on centers except in cases of concealed valley flashings and similar situations where the copper is also held by the roof covering, in which cases a spacing of 24" on center is adequate.

For specification of cleats, see specifications, sub-section 7a on p. 46.

nails

Nails used with a wood or nailing concrete laying surface should be flathead, barbed, wire slating nails, a minimum of 1" long, and of not less than 12 gauge hard copper

or brass. Surfaces with poorer nail-holding qualities require longer, stronger nails. For the right nail to use with such materials, contact the manufacturer.

Nailing applies only to cleats or to strips of copper 12" or less in width. One edge only should be nailed to permit freedom of expansion perpendicular to the line of nailing. Nails should be spaced no more than 3" on center to provide continuous resistance to thermal stresses.

For specification of nails, see specifications, sub-section 4c1 on p. 46.

screws

Screws should be of hard copper or brass. They should have round heads, because round-headed screws have flat seats which will not puncture the copper. For further protection of the copper, a lead washer should be placed between it and the screw head. Where there is danger of water penetration, as in a gutter lining, small copper caps are soldered over the screw heads.

Expansion shields used with copper work should be lead sleeves.

For specifications of screws and expansion shields, see specifications, sub-sections 4c2 and 4c3 on p. 46.

For spacing of screws in gutter linings, see specifications, sub-section 14c on p. 49.

COPPER SEAMS AND JOINTS

A seam or joint in copper may be rigid or loose depending upon its intended function.

The word "seam" applies to every kind of copper-to-copper joinery. "Joint" is applied only to expansion joints. The following discussion is divided, therefore, into "Rigid Seams" and "Loose Seams and Joints."

rigid seams

Seams are made rigid by riveting, soldering, or a combination of the two. The more positive seam for water tightness is the soldered seam. A seam may be both riveted and soldered. Soldering produces a structurally sound joint for copper up to 20 oz. For copper over 20 oz., riveting is desirable. Seams which are soldered should be pre-tinned to produce a stronger bond.

The recommended rigid seams are illustrated on the opposite page.

For specifications of solder and flux, see specifications sub-sections 4d and 4e on p. 46.

For specifications for tinning and soldering, see specifications sub-sections 7b and 7c on p. 46.

loose seams and joints

Various seams and joints have been devised to permit expansion and contraction of lengths of copper. They work in one of two ways: they slide or they flex. The loose-lock seam is characteristic of the sliding type. The batten seam is characteristic of the flexing type. Both types are used for copper-to-copper seams and joints and building expansion joints.

The seams and joints shown on the opposite page are of the copper-to-copper type. They may be made watertight by the use of a sealant, such as butyl, polysulfide, silicone, or urethane, which will not restrict movement.

See pp. 38 and 39, for details of building expansion joints.

See specifications, sub-section 10 p. 48 for specifications of building expansion joints.

See specifications, sub-section 13c for specification of cross seam, p. 49.

A copper cleat

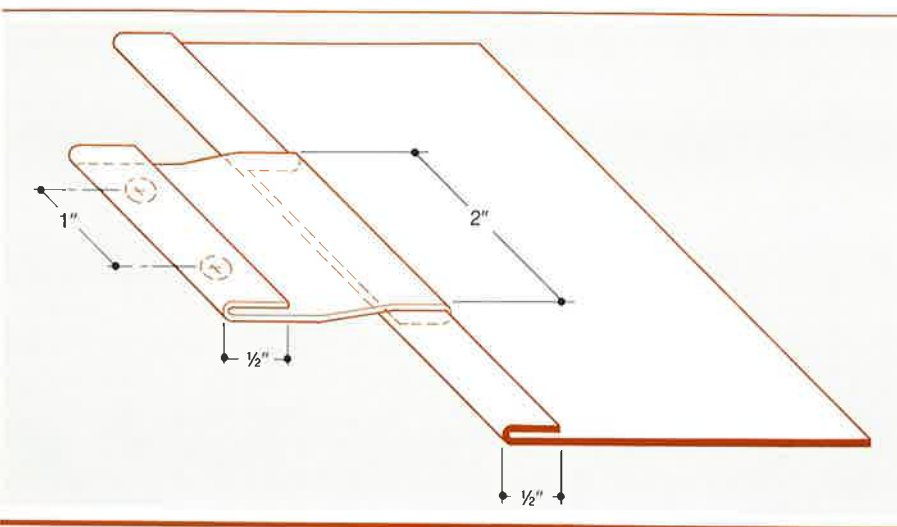

Rigid seams

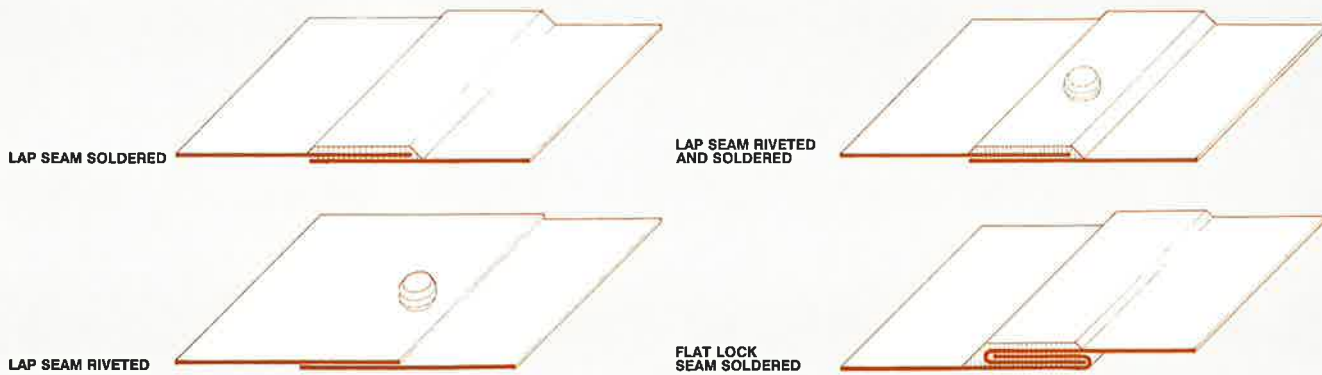

Loose seams and joints

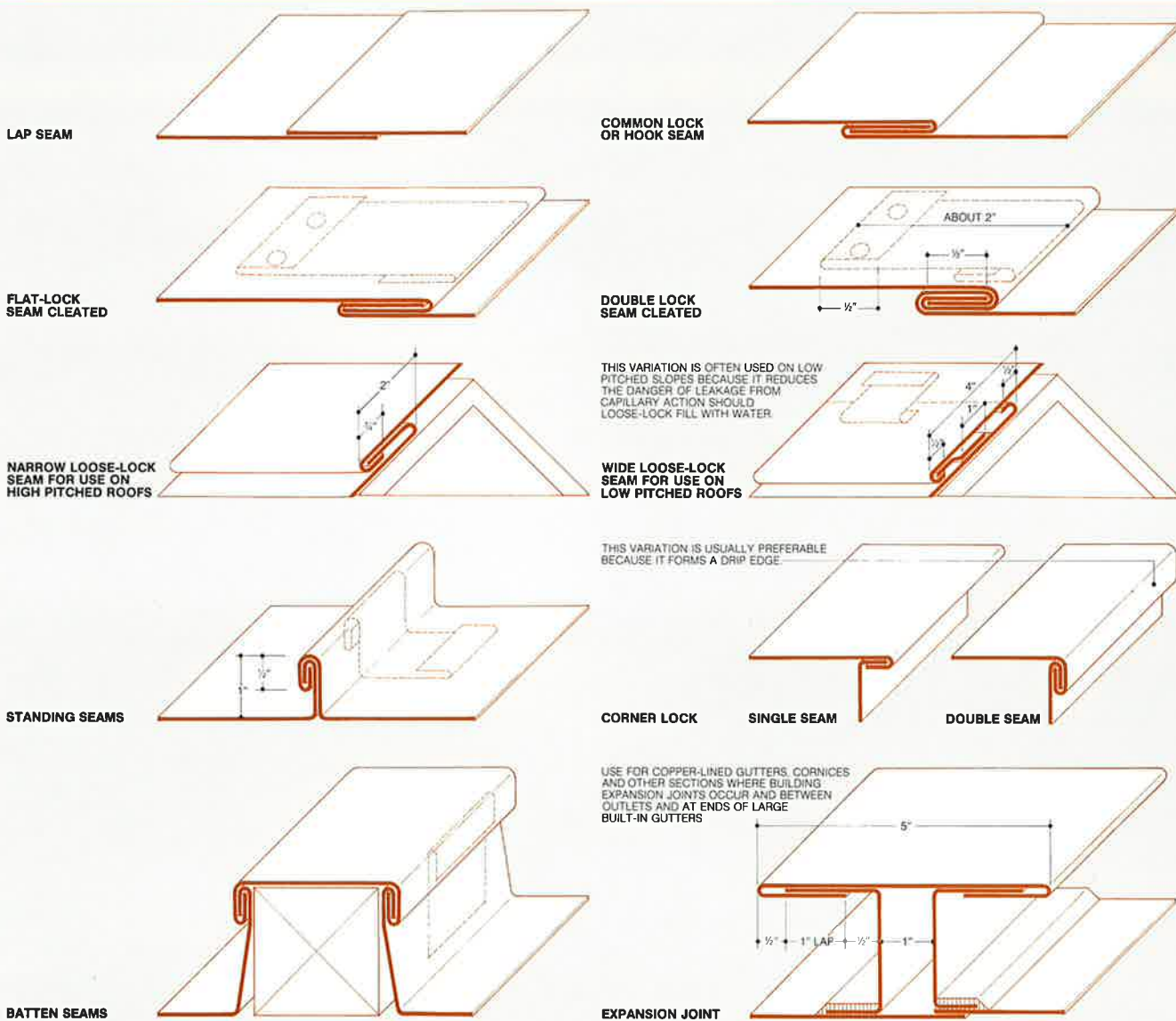

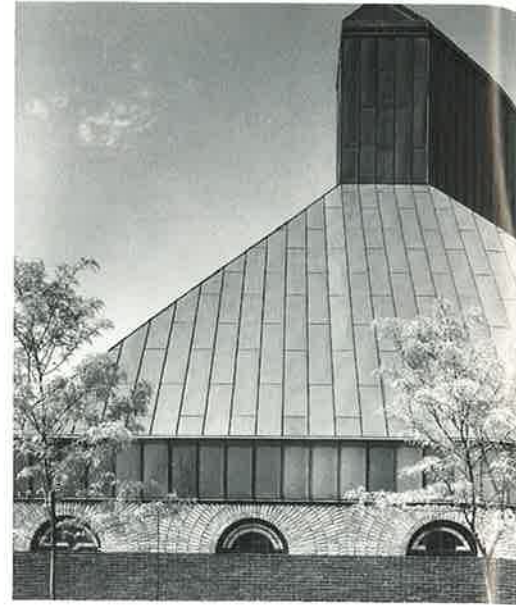
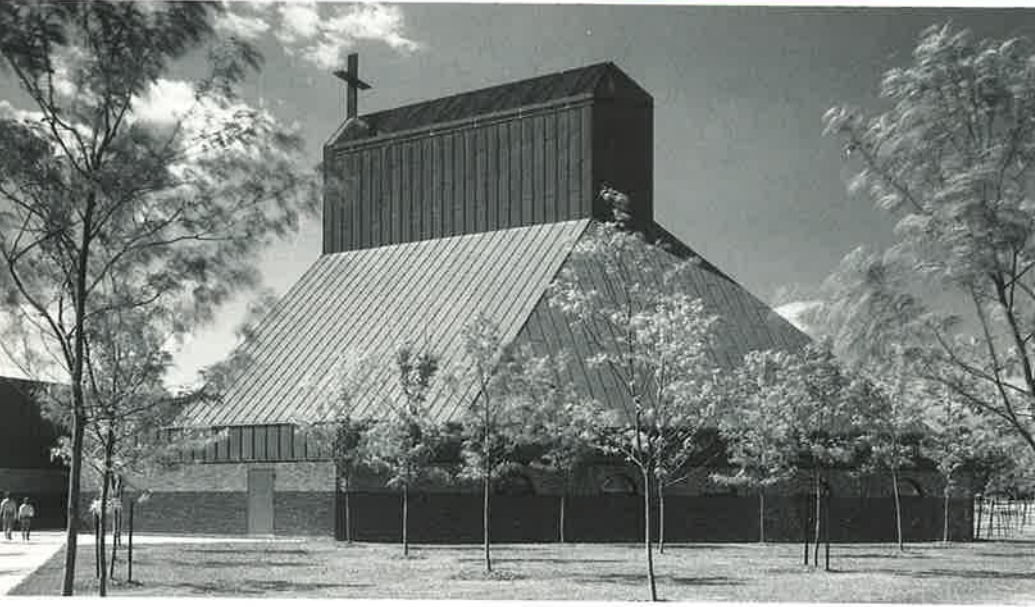

EDWARD LARRABEE BARNES

As befits a material which has been associated with fine architecture over the years, the copper roof of Edward Larrabee Barnes' Cathedral of the Immaculate Conception is part of a design concept which draws on history. While the Burlington, Vermont cathedral is not large, it was meant to present an assertive image. Barnes wanted to draw some formal inspiration from H.H. Richardson's Billings Library, an earlier Vermont landmark. By expressing the bold forms and masses of the roof and fascia planes in standing seam copper, the architect reinforced the upward sweep and intensified the significance of the church—its presence—yet achieved a bold, simple, and serene power.

For years, Barnes has been recognized as the master of quiet, powerful forms uncongested by troubling extra pieces, connections, corners, or overlaps. Although the details for standing seam roofing on the cathedral uphold the industry standards for such applications, the Barnes office developed some innovative detailing for special features. The minimal resolution of the intersections of the copper roofing with the cross incised in the upper rear wall of the main worship space are shown at the left. They are a reaffirmation of the architect's well-earned reputation for excellence in simplifying what could be a difficult confluence of parts.

Together, the seven-foot line established by the copper roof, the two bands of different colored brick, and the recollections of Romanesque arch forms have successfully joined present-day innovation with the appropriate amount of respect for, and reference to, the past.

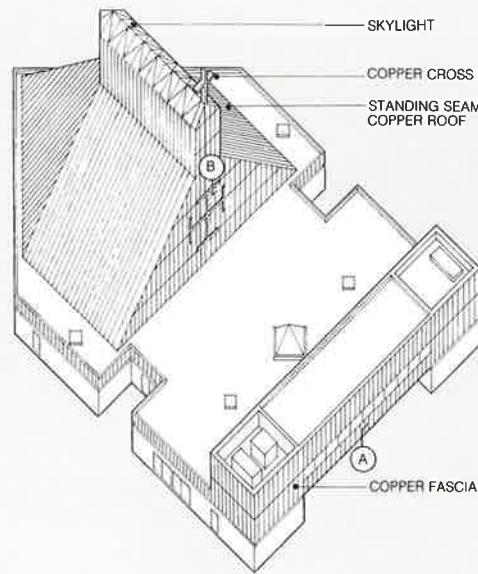

AXONOMETRIC OF CATHEDRAL

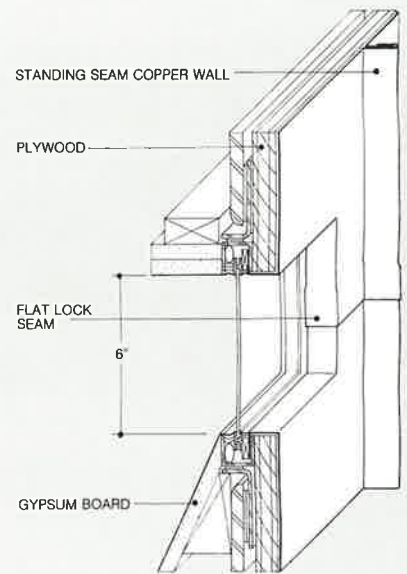

SECTION B. CROSS WINDOW

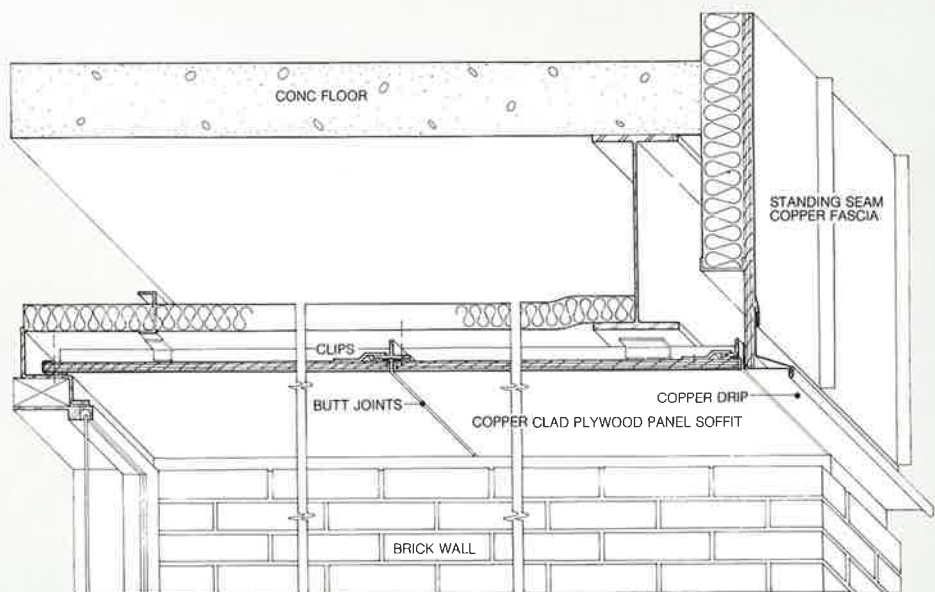

SECTION A. SOFFIT AND FASCIA



EERO SAARINEN & ASSOCIATES

Eero Saarinen never settled into a distinct design image in his works; the common factor in everything he did was his recognized genius for new, poetic solutions to individual problems—in short, for innovation. In the expressive formal statement that is his North Christian Church, Columbus, Indiana, Saarinen sought to “make the Church all one form: all the tower.” It was important that the visual experience of this form reflect the cohesive qualities the architect sought. Thus the selection of lead-coated copper to cover the main roof members, spire, gutters, and fascia. Along with the concrete and blue-gray slate of the building’s base and roof elements, the arches, trim, and spire seem to outline and exclaim the whole formed of the parts.

Carried down to the finest detail, the roof of this timeless church combines design decisions that accommodate functional realities with elegant formal qualities. Water runoff from the arches or water driven across the roof by wind is collected in small gutters running down the edges of the arches. The main eave gutters which collect all of the roof water are drained by copper leaders at the arch intersections; the leaders in turn empty into catch basins in the concrete walls. Electric resistance heating prevents ice formation in the leaders.

As is always the case, copper was selected here for specific aesthetic and functional roles. It was one key element in helping Saarinen achieve “the gradual building up of the sheltering, hovering planes becoming the spire.” With this accomplished, he added a jewel to the outstanding architectural saga for which Columbus is becoming widely known. The North Christian Church can be counted on to provide an inspiration to the congregation, and to visitors, for years to come.

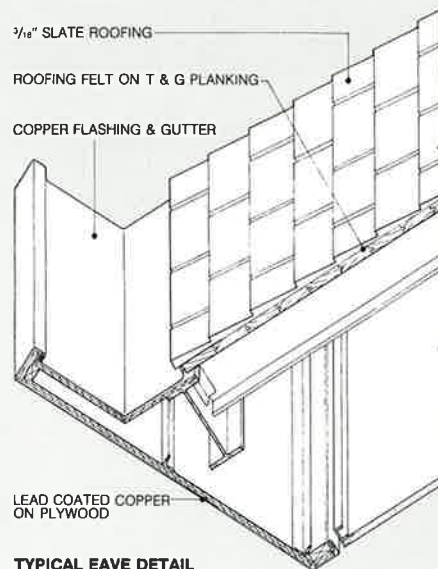

TYPICAL EAVE DETAIL

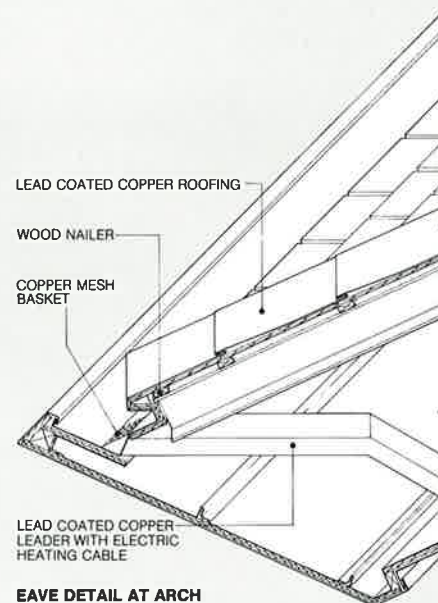

EAVE DETAIL AT ARCH

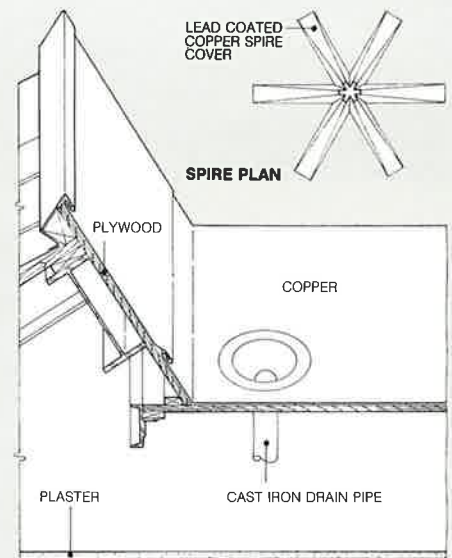

SKYLIGHT WELL

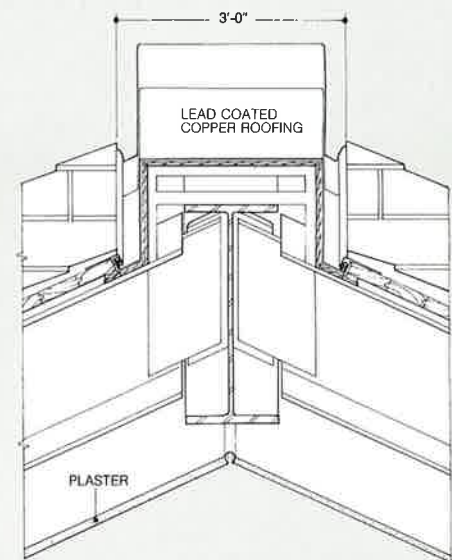

CROSS SECTION AT ARCH

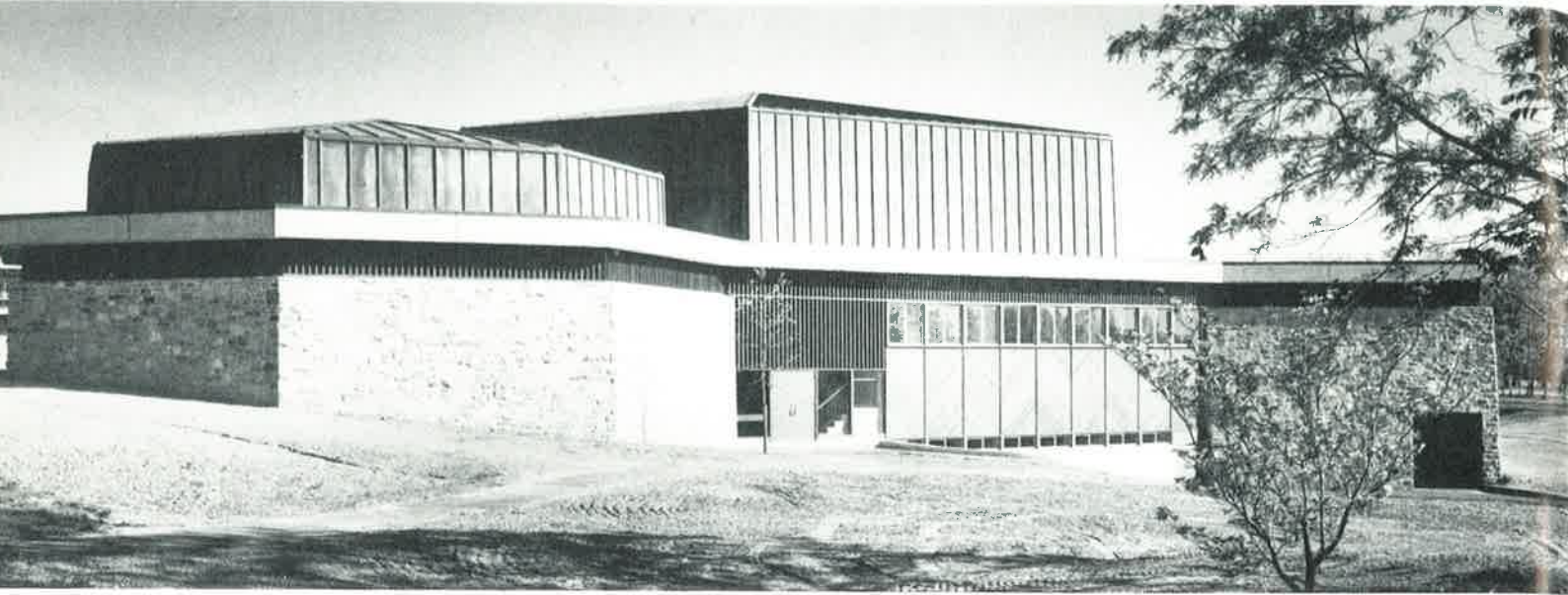

PIETRO BELLUSCHI IN ASSOCIATION WITH ROGERS, TALIAFERRO, AND LAMB

Pietro Belluschi has always been known for the warmth and elegance his buildings convey. Usually accomplished through the use of such materials as wood, field stone, and copper, this natural ambiance comes through in Belluschi's many designs in association with other architects. The Goucher College Student Center, done in association with Rogers, Taliaferro, and Lamb (now RTKL Associates), follows the Belluschi tradition for sensitivity and fine detailing.

With two main assembly areas, the auditorium and the lecture hall, the special functions wing expresses these spaces with raised batten seam copper roofs. The larger auditorium roof, hexagonal in plan, is played off against the smaller octagonal lecture hall form, taking on different compositional aspects as an observer moves around the building.

Faceted planes that form the roof massing are joined at subtle but heavier intersection mouldings, allowing the battens to terminate gracefully for each plane. Along the edges of the flat portion of the roof, an elegant copper gravel stop is set cleanly into a reglet along the top of the stone fascia. The result is a clean, crisp, and quiet roof edge expression.

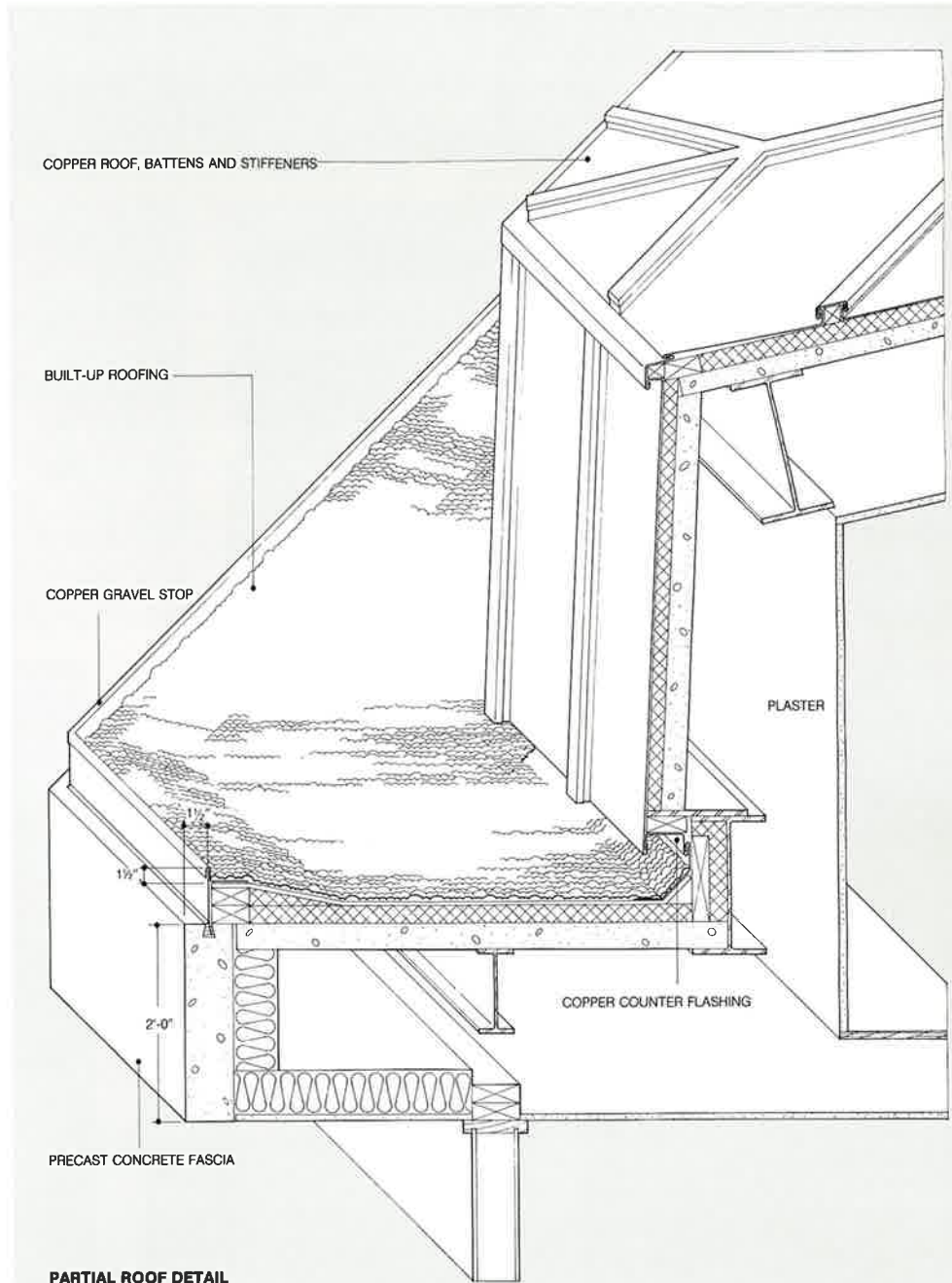

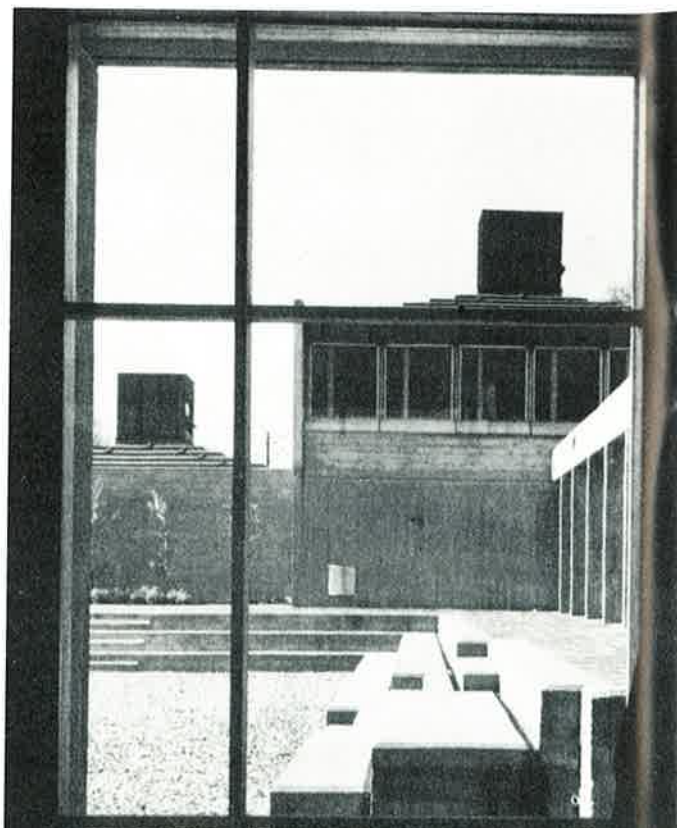
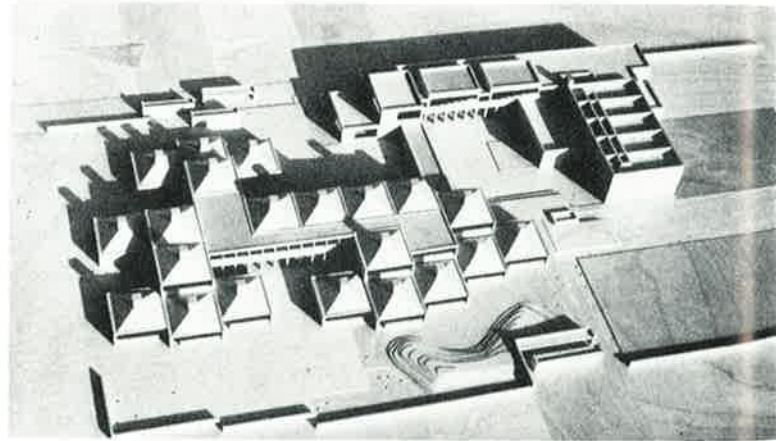
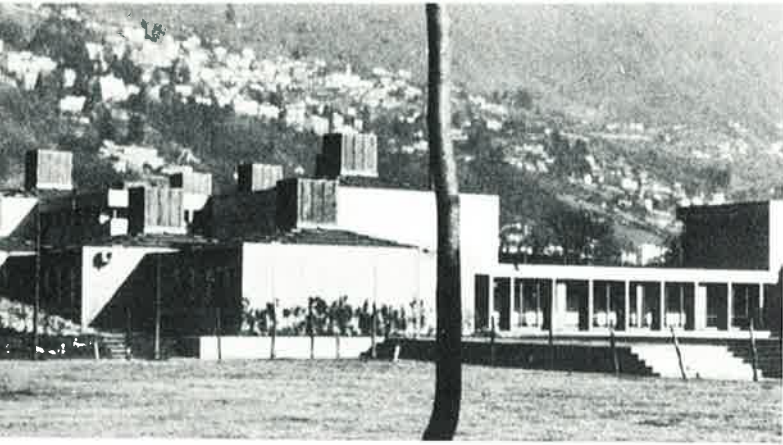

DOLF SCHNEBLI

Since the use of copper in buildings, like the use of all materials, can be traced in history back to other lands, it is fitting to view an example of a modern facility in Europe. This junior high school in Locarno, Switzerland, by architect Dolf Schnebli, not only broadens the geographic range of projects shown, but introduces another application of copper. Lap joints combined with transverse battens form the roof, and standing seams are used for vertical elements.

This school complex, while relatively large in overall area, was designed in smaller square classroom units, each with its own copper pyramidal roof. Atop each is a cubical ventilator/skylight "chimney" form, punctuating the roof profile and recalling the scale of the Swiss village climbing the adjacent hillsides.

Continuous lapped copper sheets run parallel to the eaves, and are bounded at the ends by the transverse batten joints, staggered because of roof and corner pitches. With the addition of standing

seam "chimneys" and fascia panels, the dramatic interplay of copper textures forms a richly orchestrated visual fabric with the rough concrete of the units. This is copper used at its best for richness, drama, and aesthetic impact. For convenience and better description, the combined detail shown below illustrates conditions at both concrete end wall and fascia, although in reality they would be on adjacent, not opposing, building elevations.

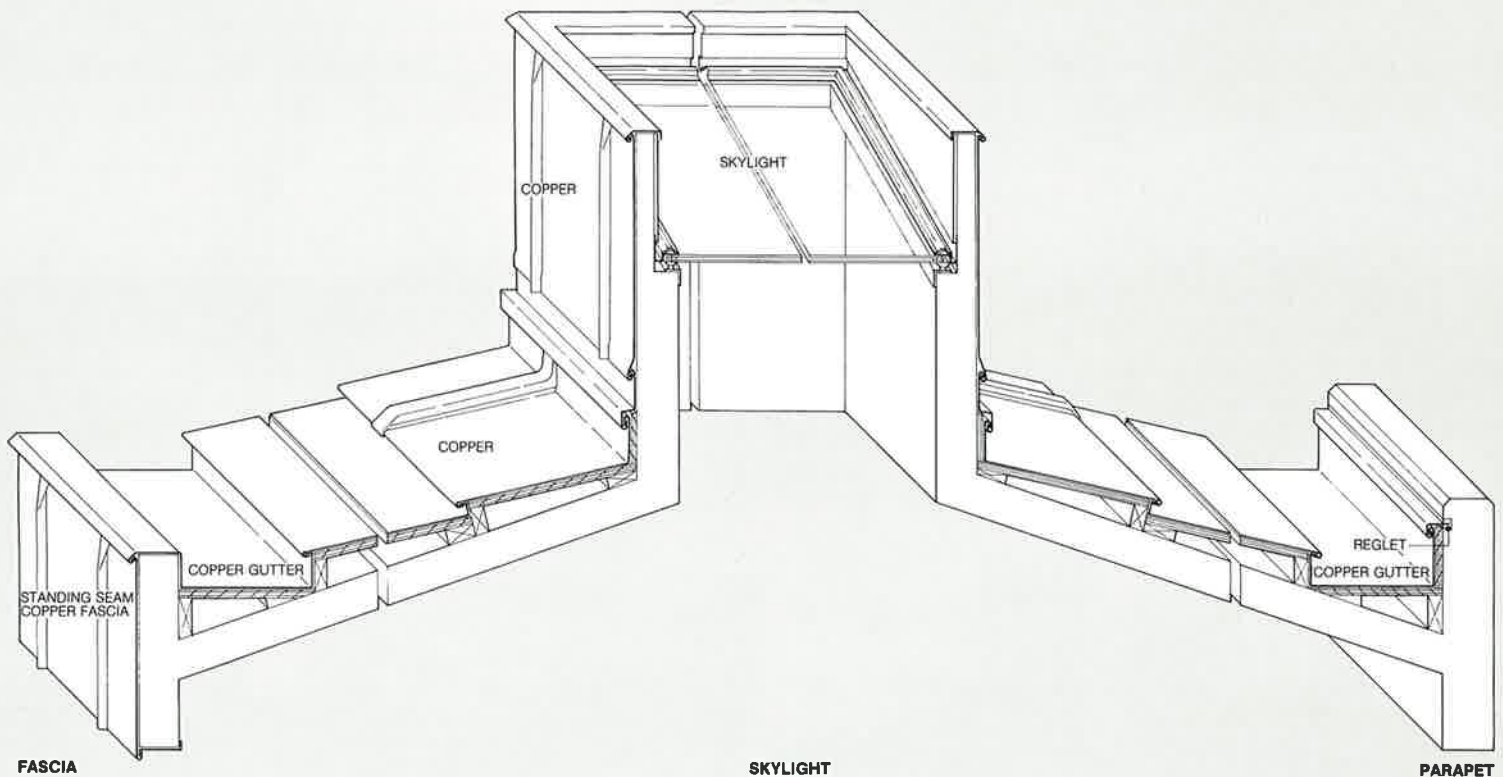



DAVIS, BRODY & ASSOCIATES

As every architect knows, it is sometimes the quiet, if not quite simple, problem that can spoil or successfully complete a good design. The design for a synagogue in a neighborhood that is largely residential calls for a restrained yet expressive solution. Davis, Brody & Associates designed the deep standing seam fascia of the Agudath Sholom synagogue, Stamford, Connecticut, to maintain a consistent character and scale, while also relating to a warm brick color. The strong horizontal fascia band also recalls the bronze glass, while unifying two visual elements expressing the main worship space and the multipurpose area across the central corridor. This auxiliary space may be opened to form additional worship space on High Holy Days.

Unifying the deep recesses, the projected walls, and the one and two-story masses, the fascia performs the deceptively simple task of giving the building a horizontal finishing note. It is the appropriate counterpoint to the strong vertical facade elements, cleanly detailed yet assertive.

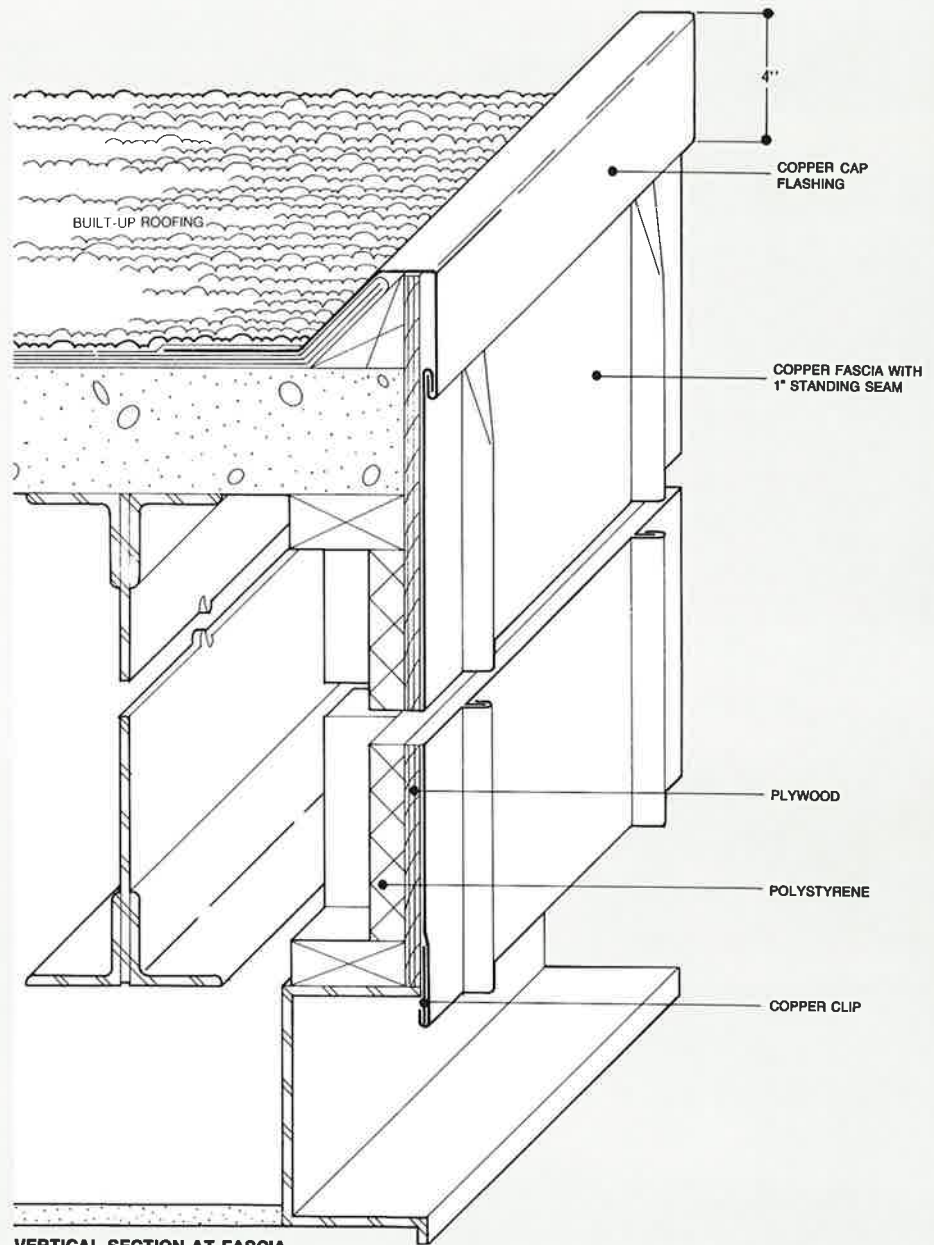

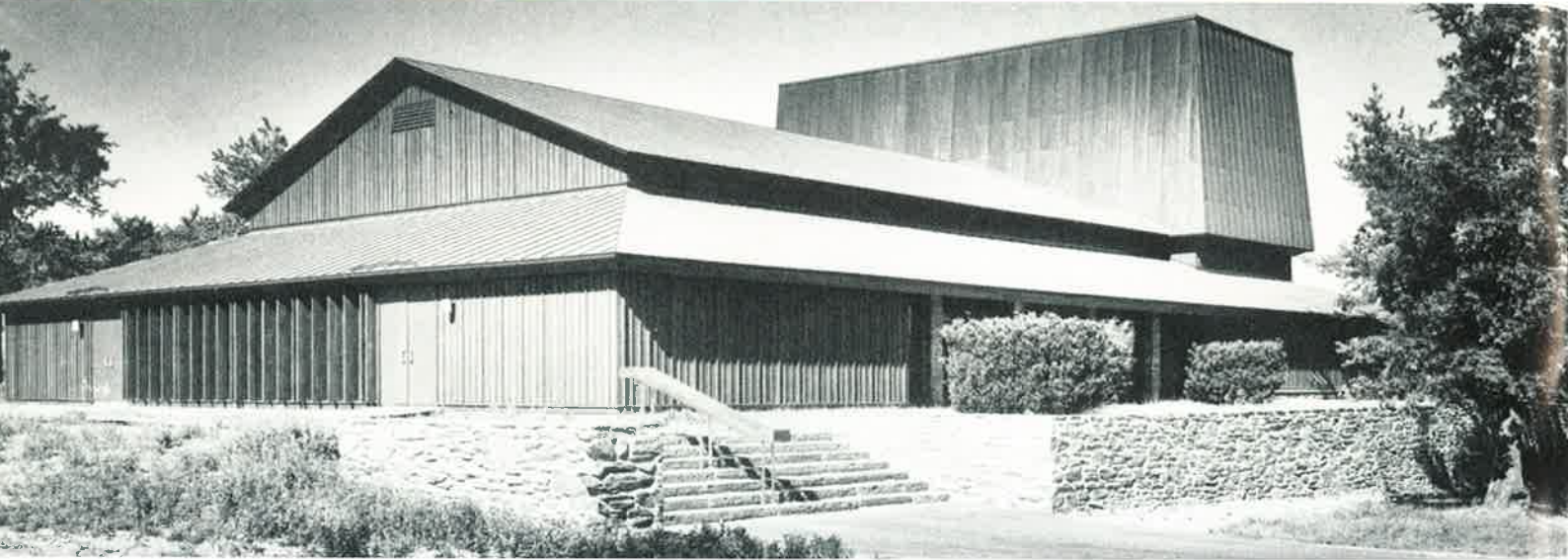

PIETRO BELLUSCHI IN ASSOCIATION WITH ROBINSON, GREEN AND BARETTA

Again combining copper with other "warm" materials—redwood and stone—Belluschi and associated architects Robinson, Green, and Baretta arrived at this serene design. The low hipped roof signals the lobby and side aisles of the Portsmouth Priory multipurpose building in Rhode Island. The higher gable covers the seating section, and the bold trapezoidal mass is over the stage. Standing seam copper roofing and continuous copper coping and edge strips show the detailing care of the architects, resulting in the deceptively simple expression.

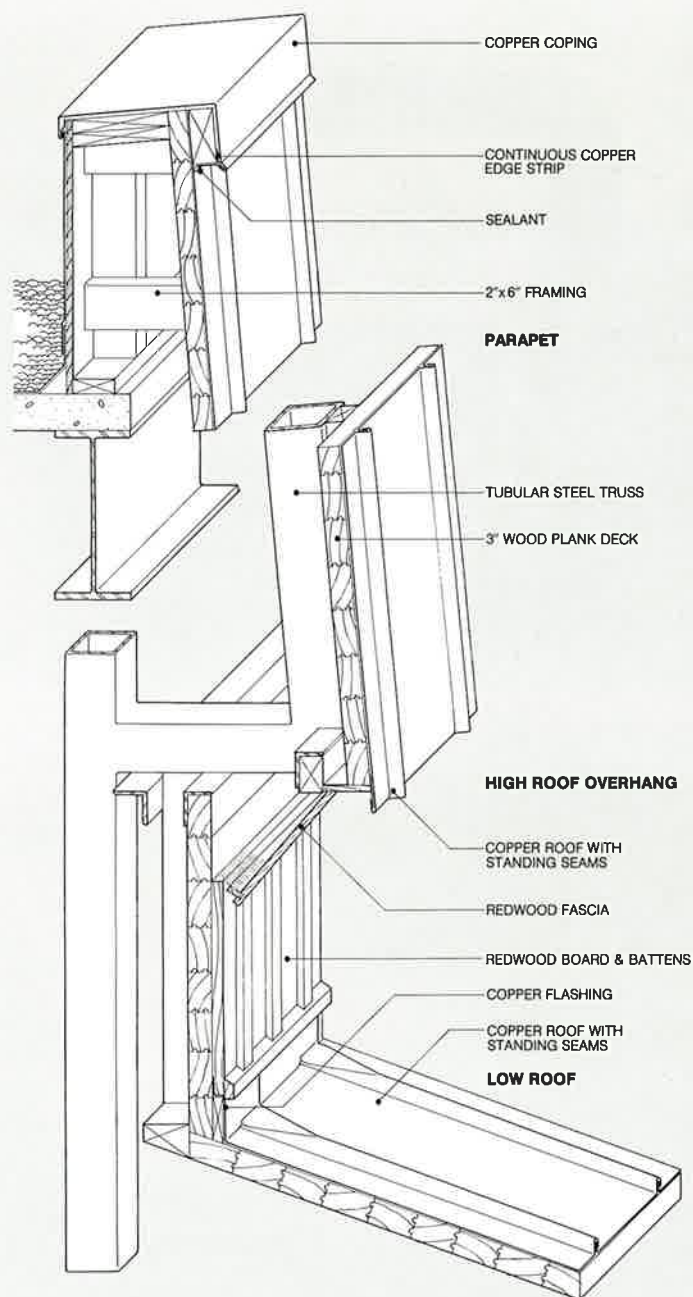

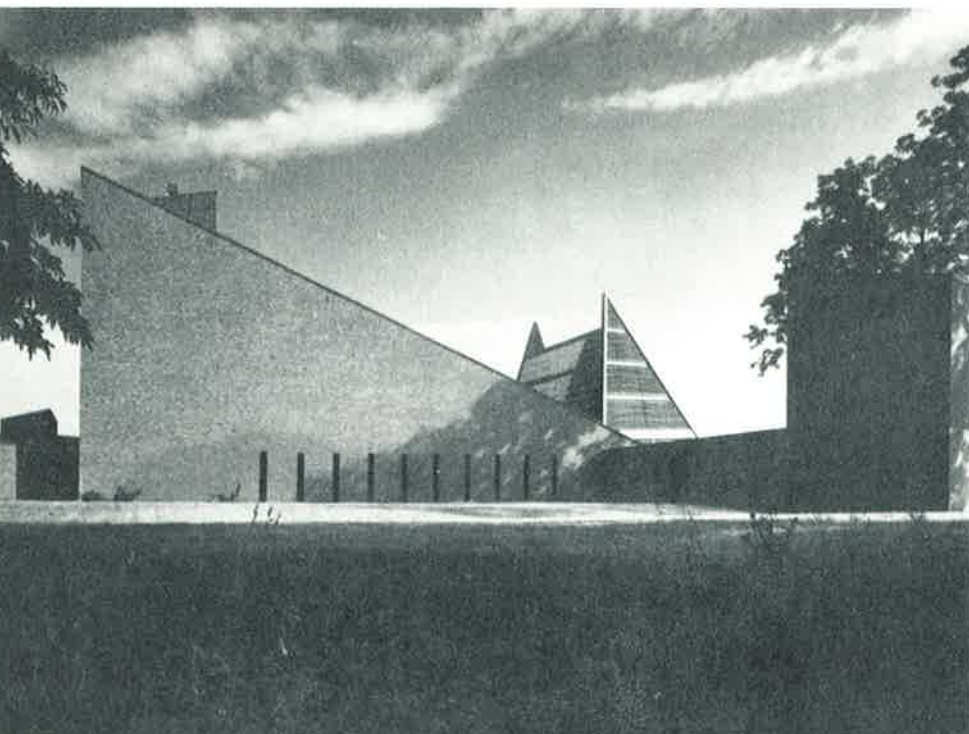
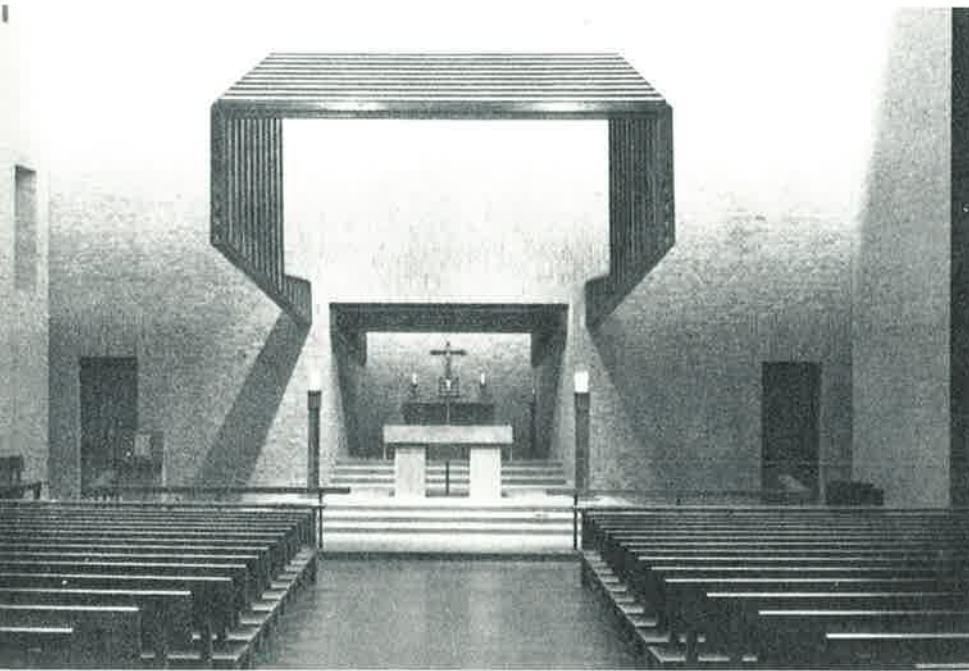
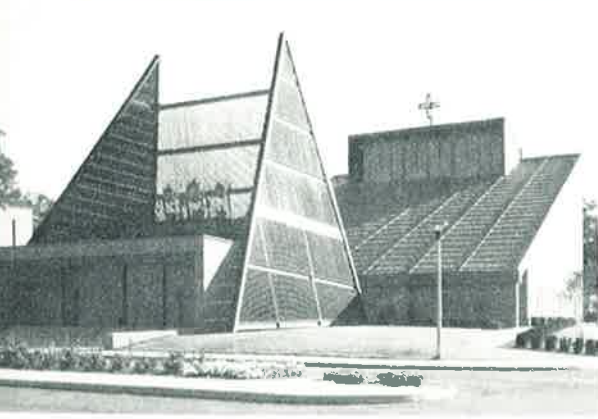

Imaginative uses of copper abound in this striking Roman Catholic parish church in Grand Rapids, Michigan, St. Jude. From the most prominent application—the entire roof—to functional, sculptural, and liturgical roles, the architects have used copper skillfully to enrich and complete the design concept. The roof comprises copper sheets with lock seams running perpendicular to the pitch direction; ridges occur every third sheet, and are divided by battens parallel to the direction of pitch.

While the roof is an extremely powerful element in the composition, the design follows through in other elegant ways. Beginning with the standing seam returns on the clerestory, copper is then carried into the skylight wells to bring a warmth to the light introduced to the worship spaces. Together with the natural woods and the pink brick, the incoming illumination helps to set the tone for a simple, powerful expression.

For the final touches, copper is called into play for the cantilevered main altar canopy and the Madonna sculpture. The altar canopy is constructed of copper sheets joined in standing seams over a plywood substrate supported by a structural steel frame. The repousse copper and brass Madonna figure is by Gerard Bonnette, and stands to the right of the main altar.

PROGRESSIVE DESIGN ASSOCIATES

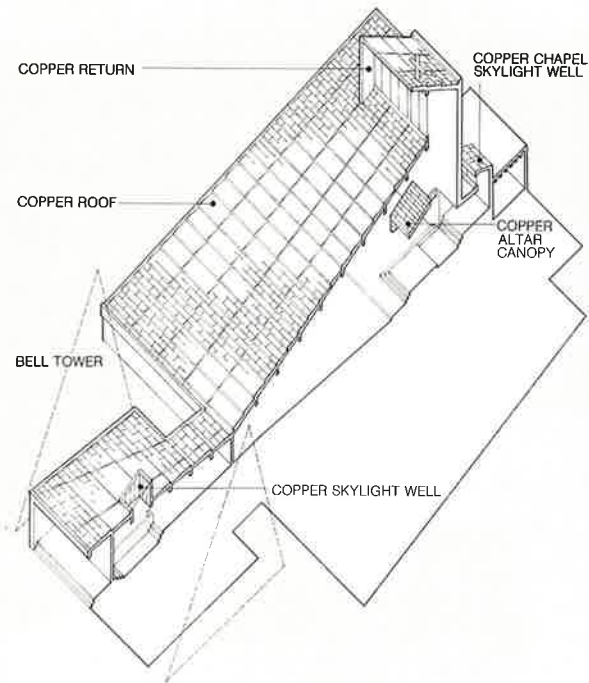

BUILDING AXONOMETRIC SECTION

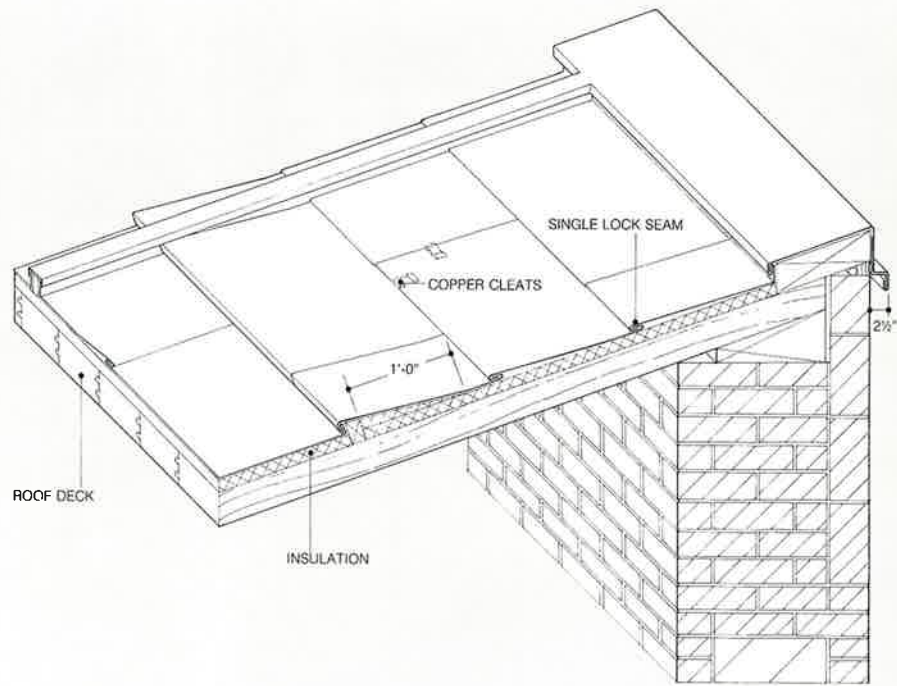

ROOF DETAIL

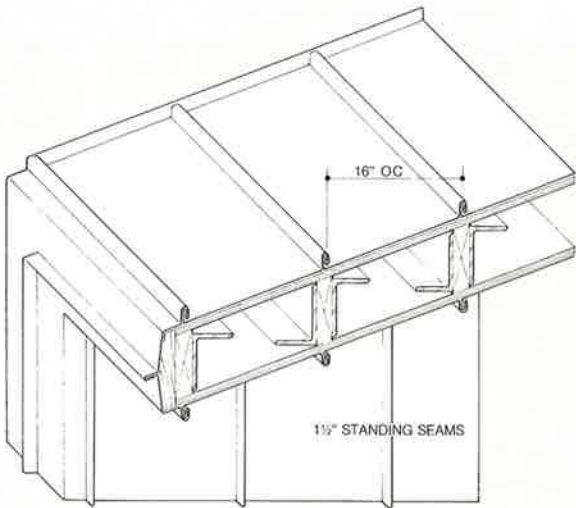

DETAIL A CANOPY

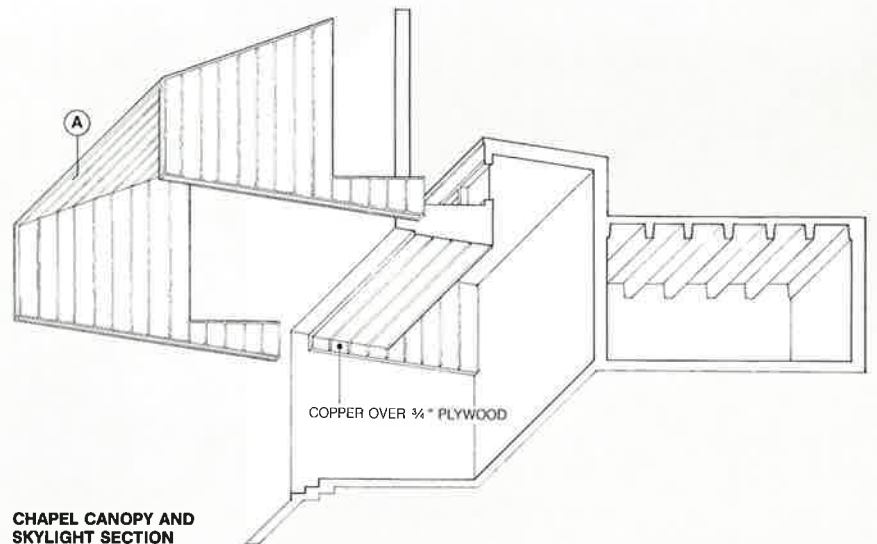

CHAPEL CANOPY AND SKYLIGHT SECTION

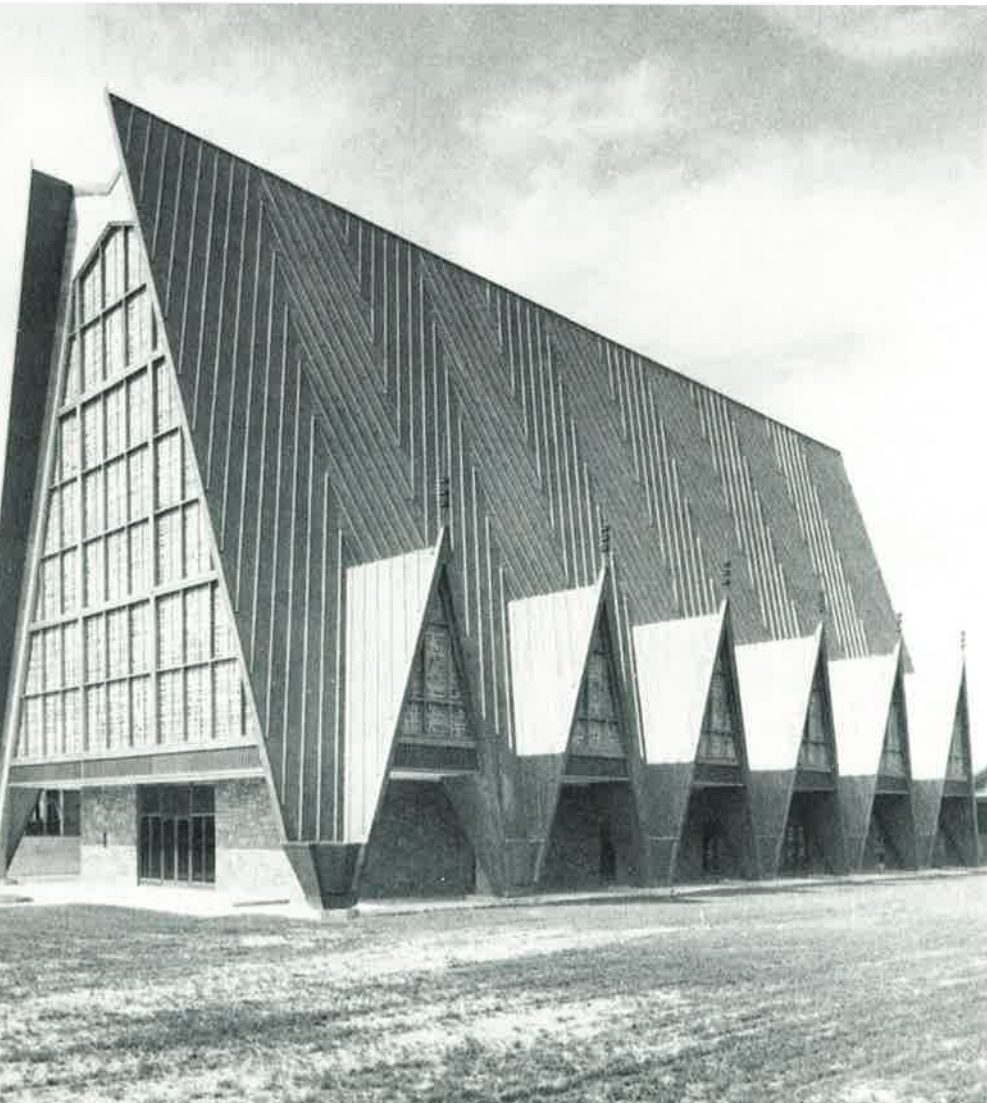

It would be hard to combine the aspects of historicism, innovation, and current use in a better mix than the design for Our Lady of the Angels Seminary in Glenmont, New York. Architects Urbahn, Brayton, and Burrows have introduced an angularity and verticality reminiscent of Gothic, while employing detail, ingenuity and design originality to achieve a fine example of copper in action. Not only is the chevron pattern batten seam roof a classic example of a function turned aesthetic, but it is combined with numerous other complementary aspects which join design and utilitarian considerations. Faceted expressions for first floor library fascias, drainage troughs, scuppers, and drain pockets join the list of unique uses for copper shown here.

At the apex of the high roof, the pitch turns to a valley, drained by two-inch pipes to the outer roof surface. From there, water is diverted along battens to the drain pockets below each chevron panel on the roof. Copper pockets then transfer water to the drain box for dissipation below grade. To be sure, the architects have used copper to multiple advantage in perfecting the design concept for this facility.

URBAHN, BRAYTON AND BURROWS

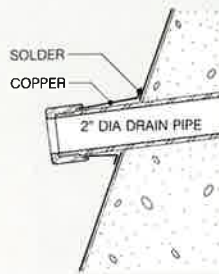
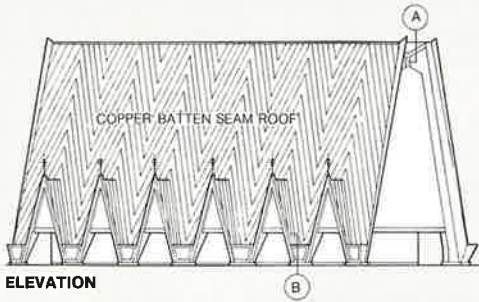

HIGH ROOF DRAIN SPOUT

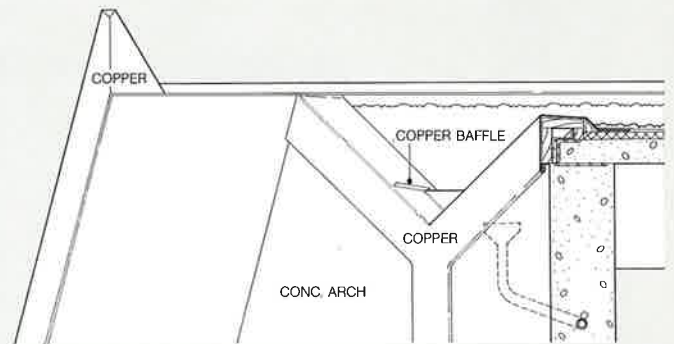

DETAIL A AT HIGH ROOF

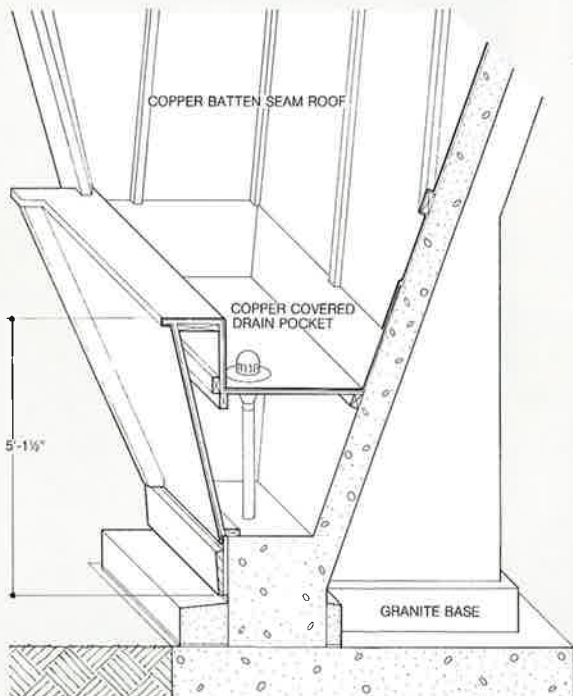

DETAIL B DRAIN POCKET

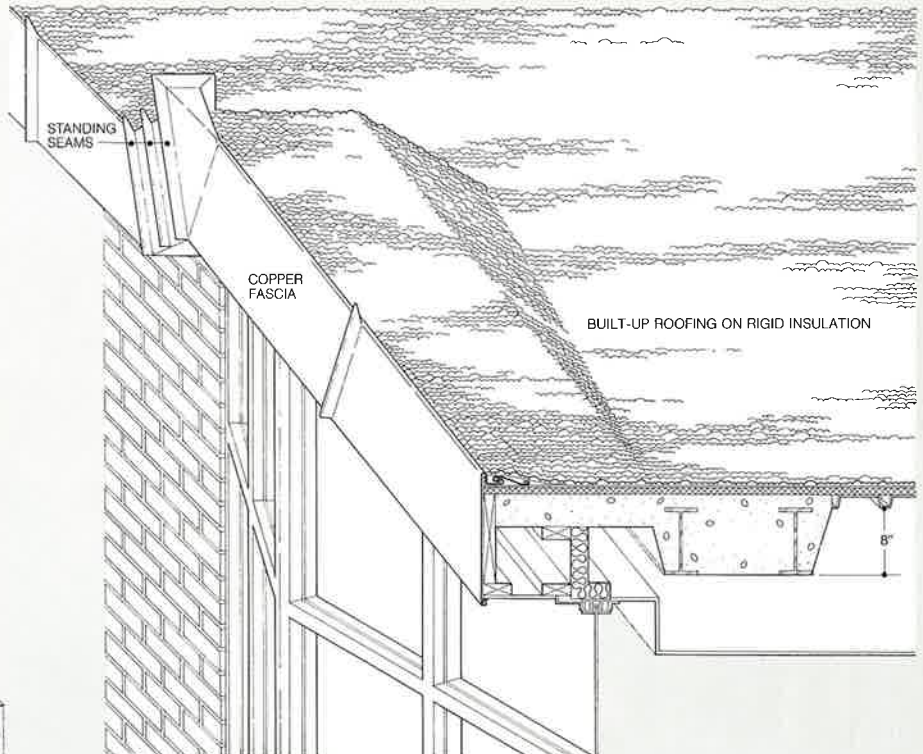

DETAIL AT LIBRARY WINDOW

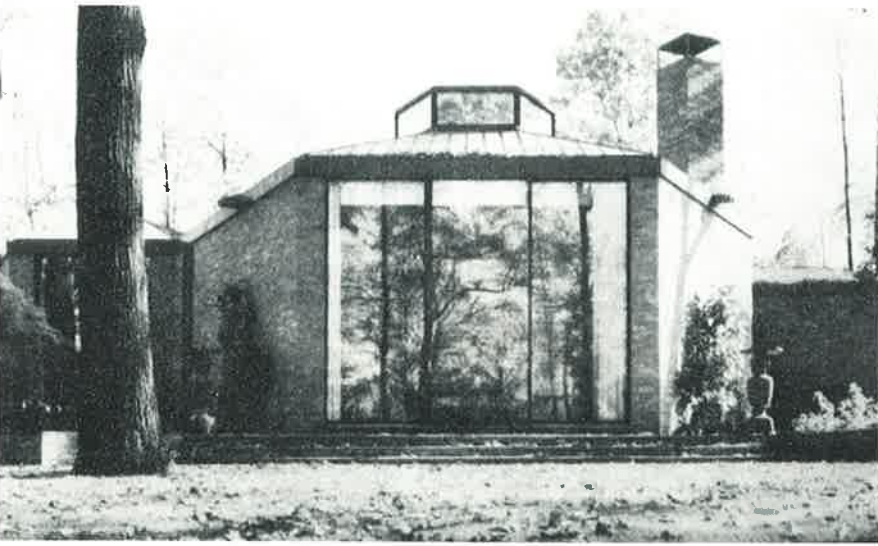

As noted before, sometimes a structure is called upon to deny its size in a given context. Geddes, Brecher, Qualls, Cunningham designed this house to do just that. Although fairly large in area, the house is broken down in scale through the plan organization, and through the use of materials that allow it to blend into the surrounding woods and area. Copper was selected for clerestory, roof, gutter, and fascia applications because of its weathering capacity and its compatibility with the brick to be used. The standing seam roof and clerestory pattern were designed to reinforce the geometric forms of the house. The gutter, which forms the continuous fascia around the structure, is punctuated by long copper scuppers—design elements in themselves.

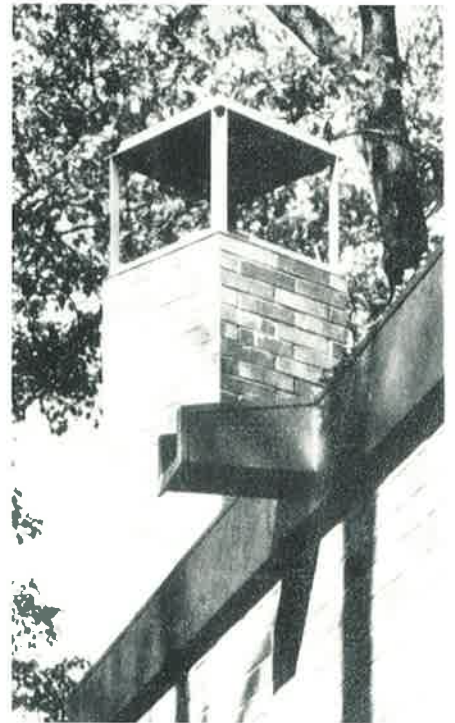

GEDDES, BRECHER, QUALLS, CUNNINGHAM

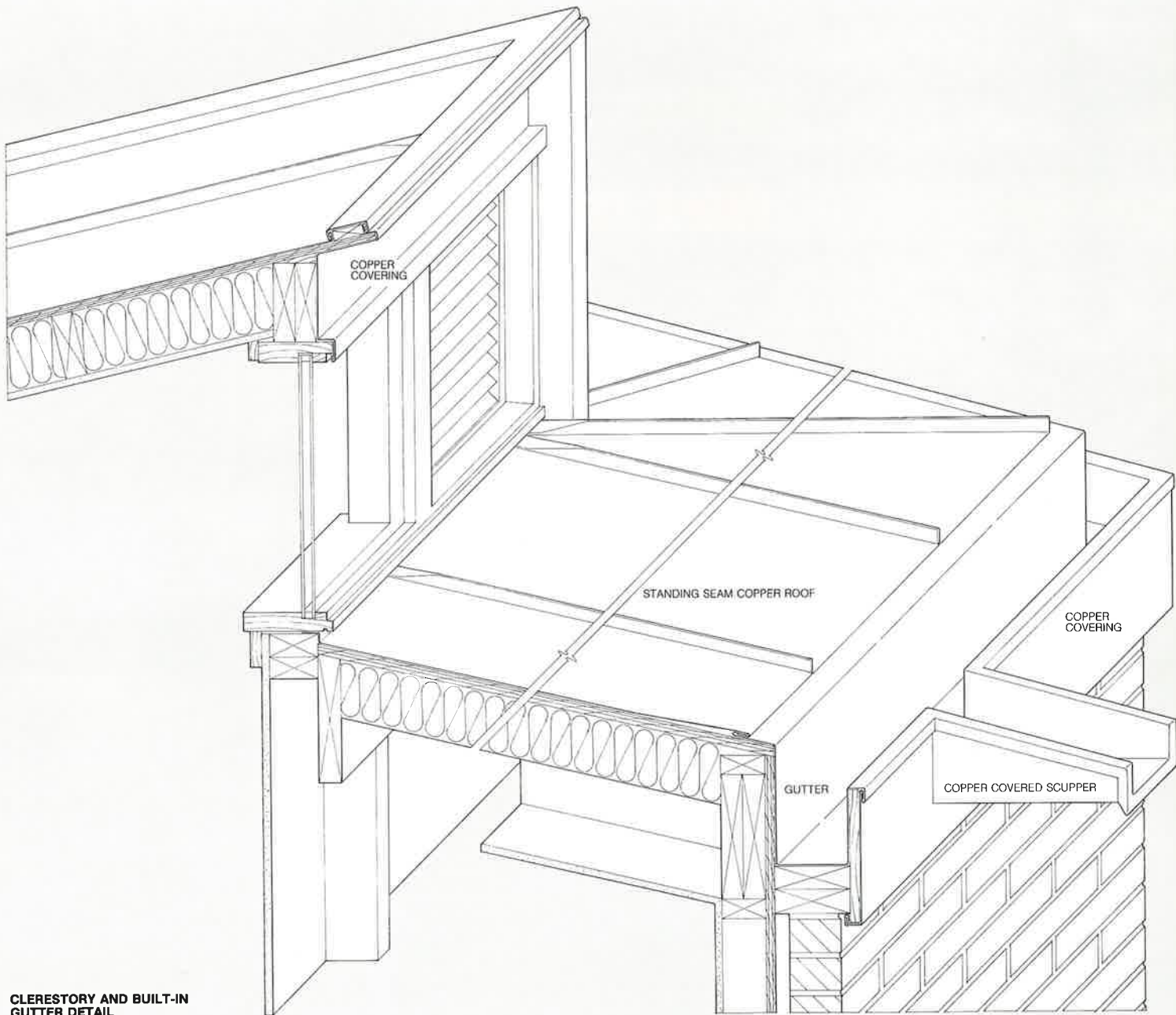

CLERESTORY AND BUILT-IN GUTTER DETAIL

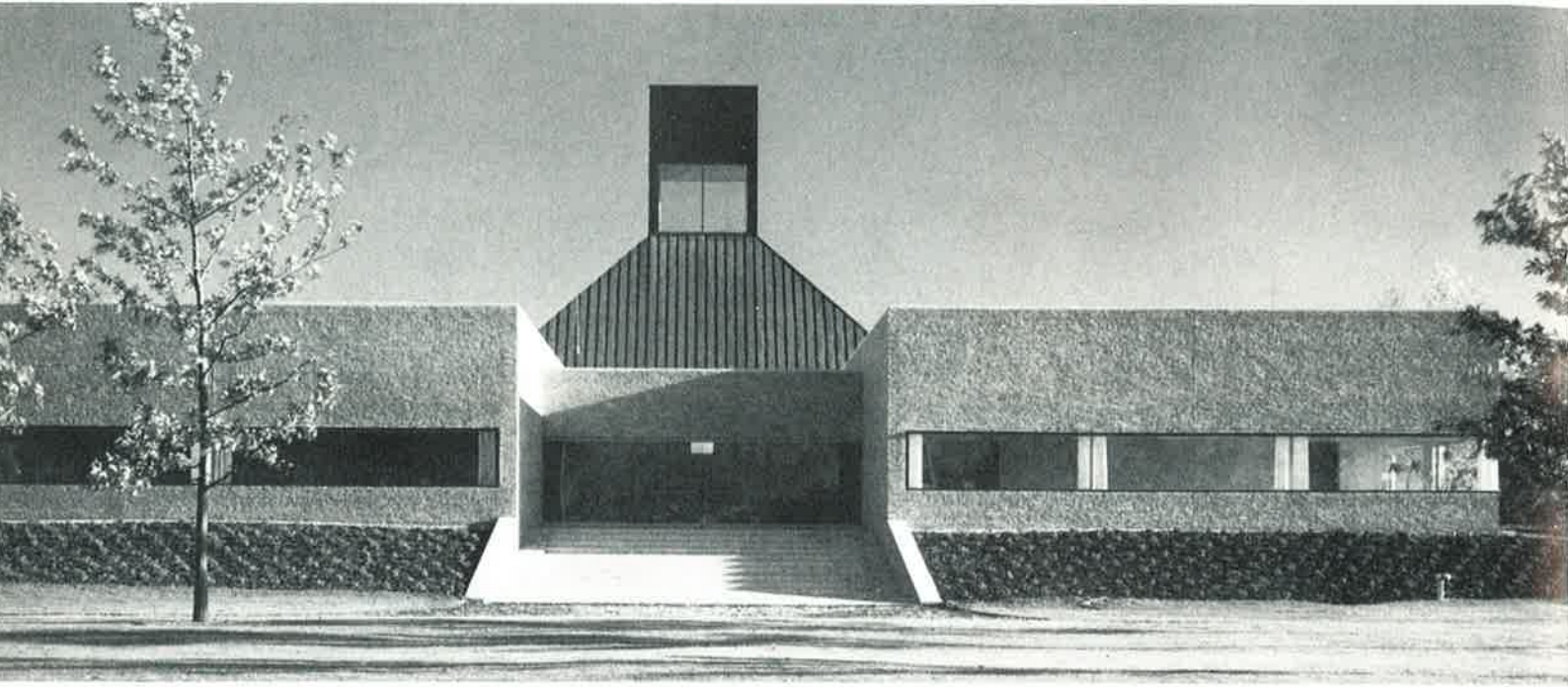

EDWARD LARRABEE BARNES

It may be significant that a number of the examples shown on the preceding pages are religious structures. It is clear that, given the concerns of a program as personal as a house or a house of worship, copper is a natural choice. Another form—this time for the celebration of plant life—looks good in copper, too. The new Botanic Garden complex in Glencoe, Illinois is another architectural landmark of Edward Larrabee Barnes. In a very different kind of a design problem, Barnes again turned to copper for the roof of the main pavilion.

It is another bold formal solution to a challenging program, that of dealing with a beautifully reclaimed swampy site, soft and asymmetrical, and yet to house a botanic garden conservatory of fairly large proportions.

The exhibition hall and canopy are of standing seam cold rolled sheet copper; the main pavilion is surrounded by ten greenhouses, forming a delightful troupe around the centerpiece. Once again, the seeming simplicity and the central design statement are accomplished in copper.

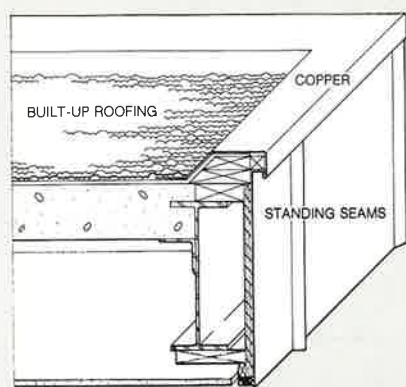

FASCIA AT ENTRANCE

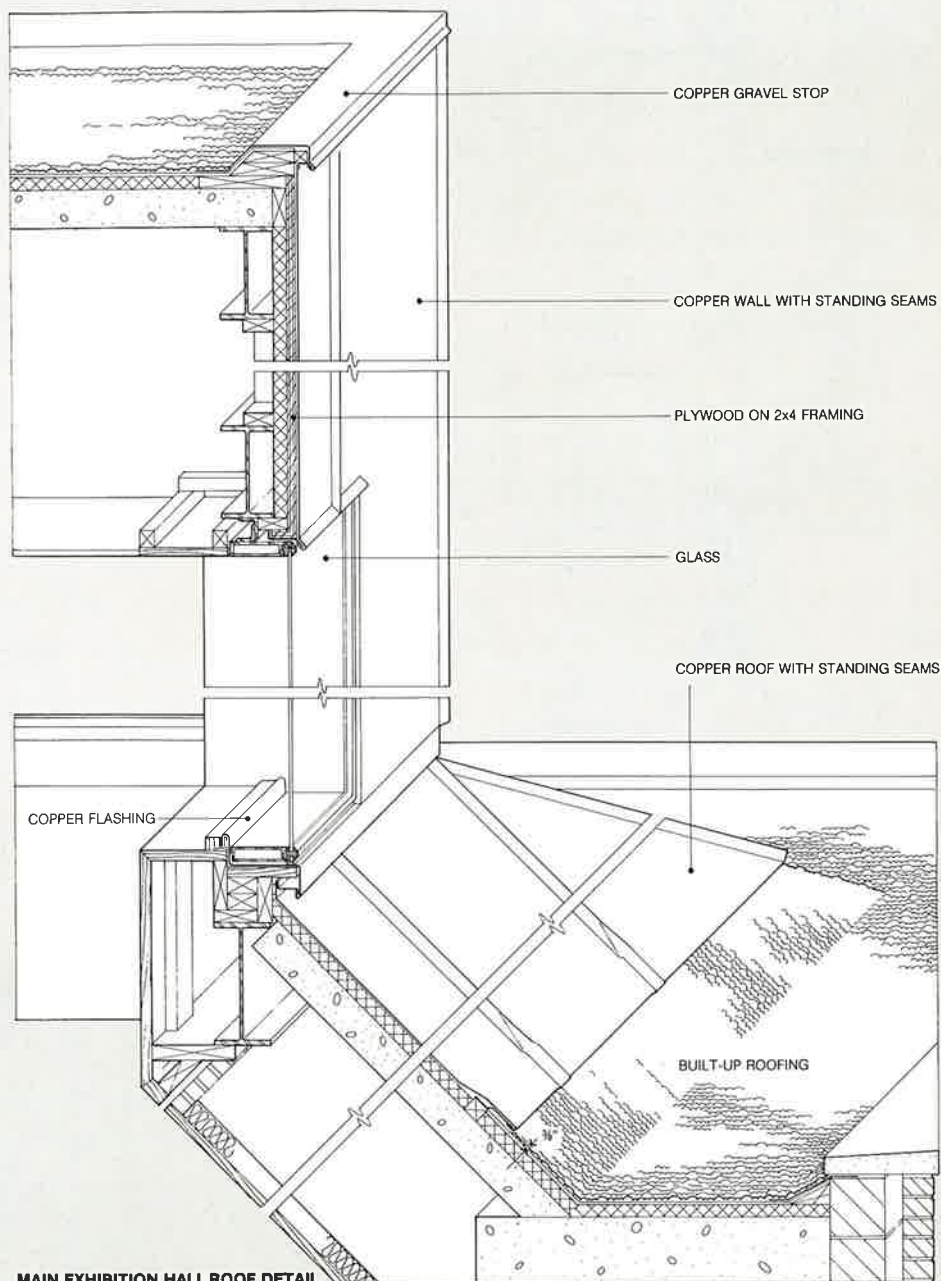

MAIN EXHIBITION HALL ROOF DETAIL

THRU WALL FLASHING AT HEADS, SILLS AND WATER TABLES

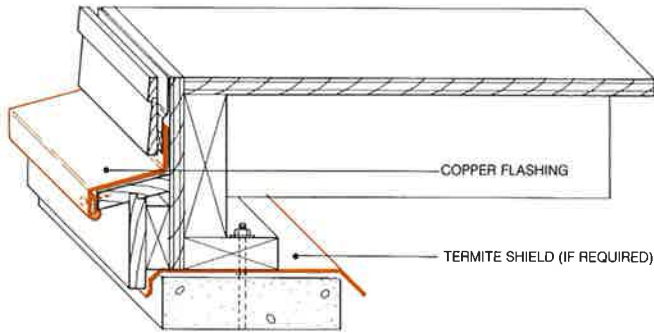

WATER TABLE

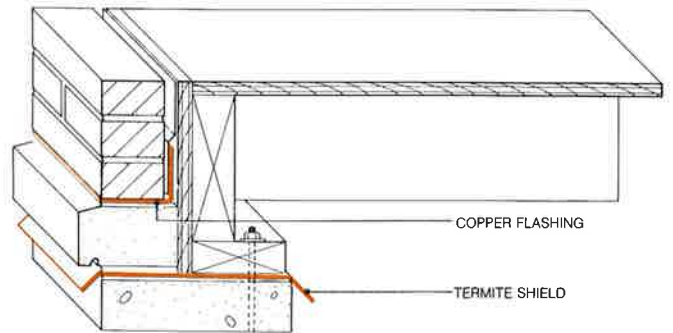

WATER TABLE

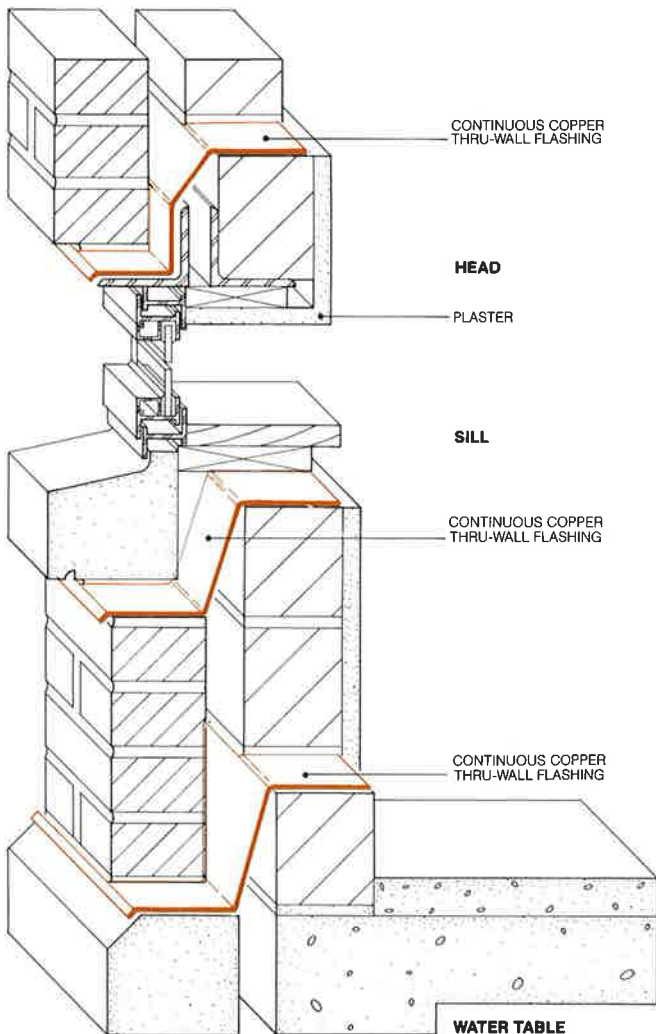

CAVITY WALL

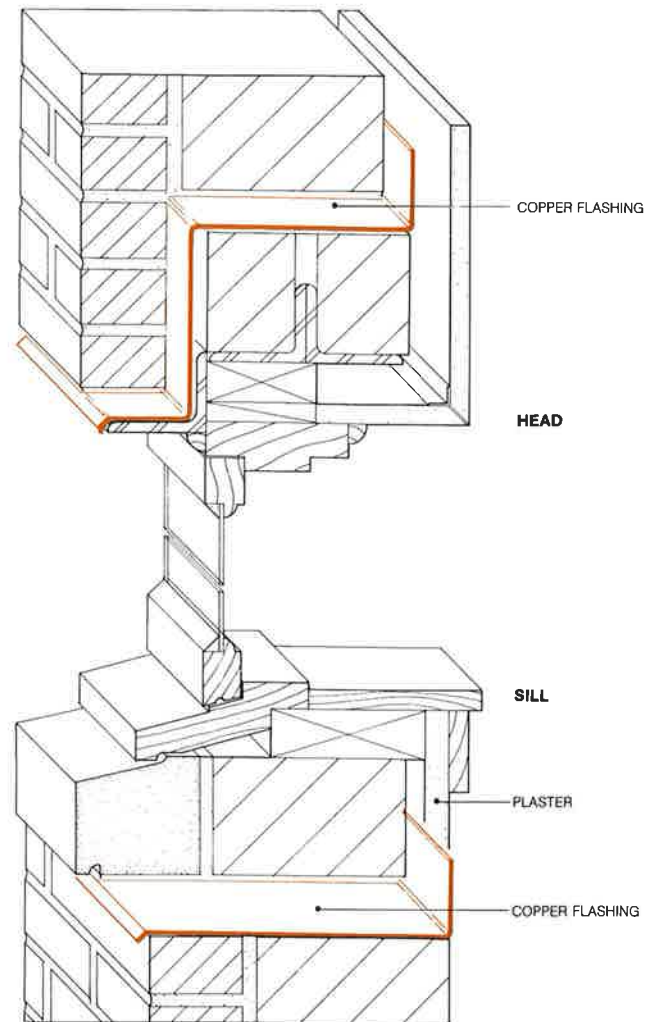

SOLID MASONRY WALL

On the following pages, you will find the detail conditions most often encountered in the use of copper. They represent the standards recommended by the industry

for the applications shown. All copper shown in these details is *cold rolled sheet copper*, and the gauge is not noted, since some applications can use one of several

weights. For gauge recommendations, refer to page 5 and Section 4, the specifications for sheet copper.

SPANDREL FLASHING AND BASE COURSE

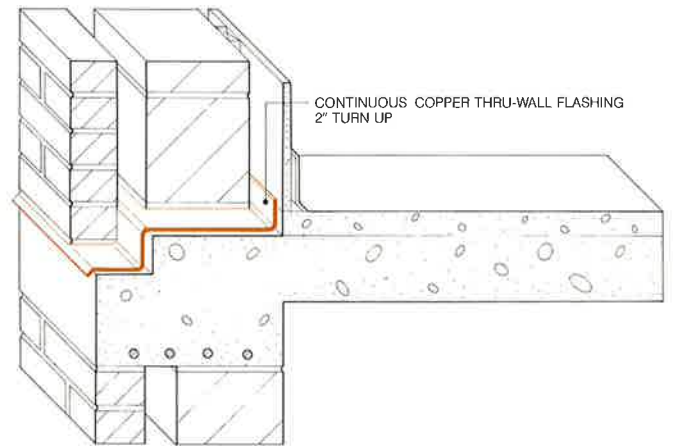
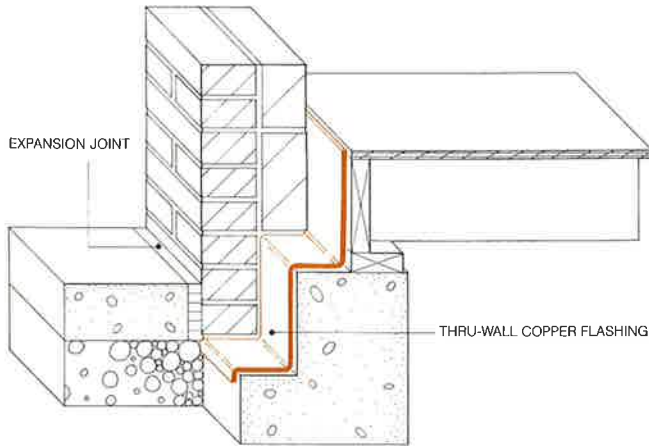

BASE COURSE AT BRICK WALL

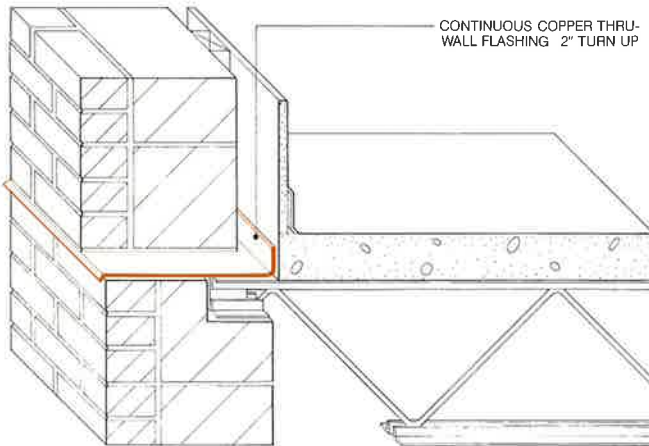

EXPOSED SPANDREL

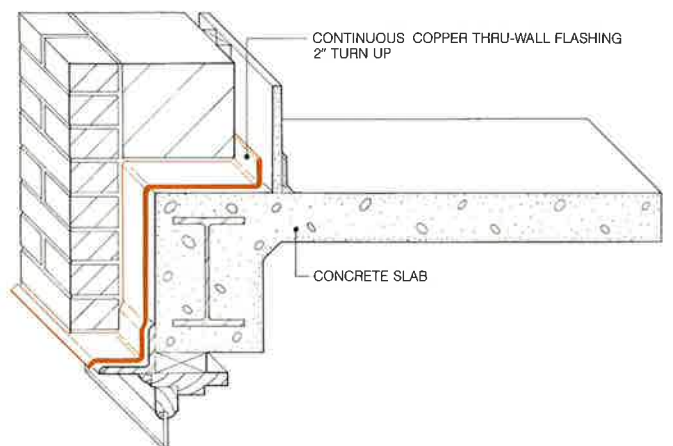

OPEN WEB JOIST IN BEARING WALL

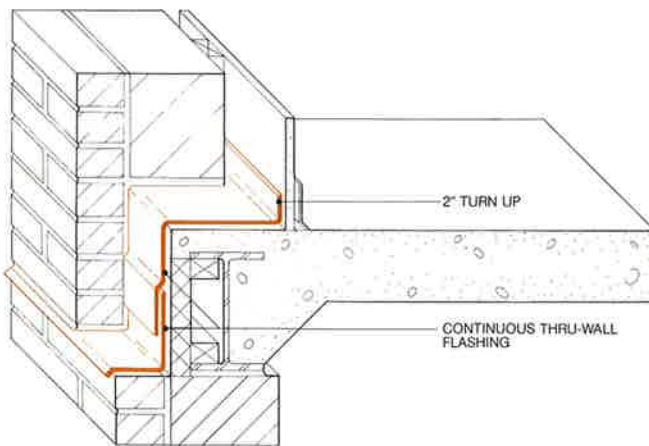

SHALLOW SPANDREL

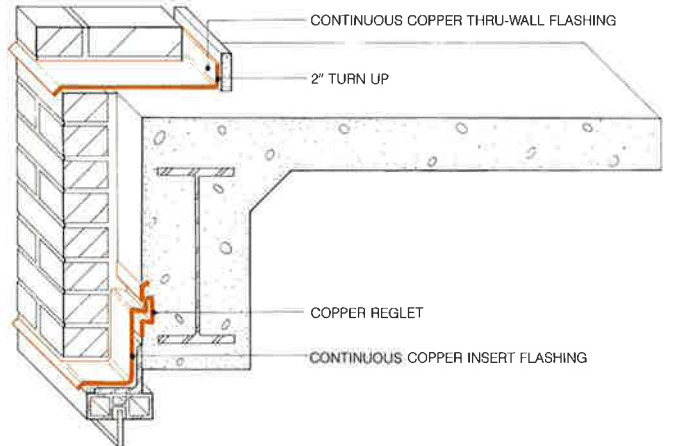

EXPOSED WEB SPANDREL

DEEP SPANDREL

FLASHING AT INTERSECTION OF FLAT ROOF WITH WALL

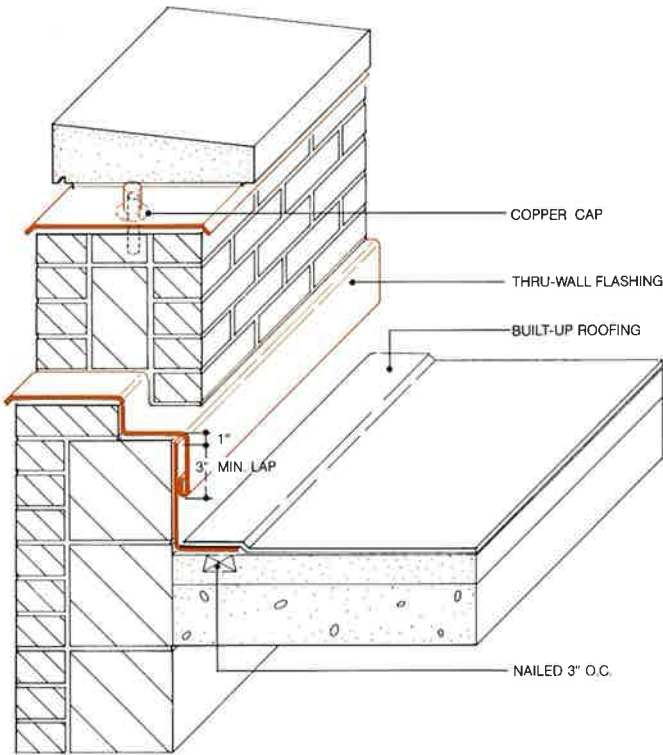

HIGH PARAPET WITH BUILT-UP ROOF

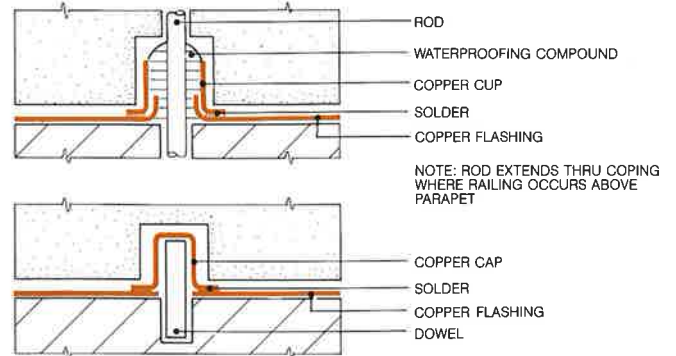

SLEEVE OR CAP FOR COPING ANCHOR

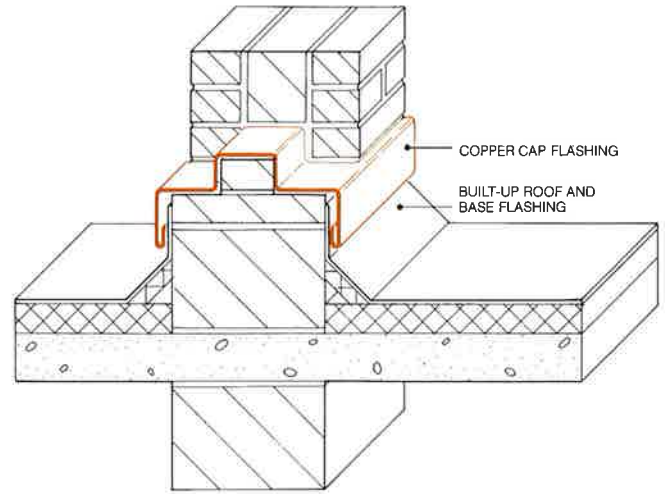

FIREWALL

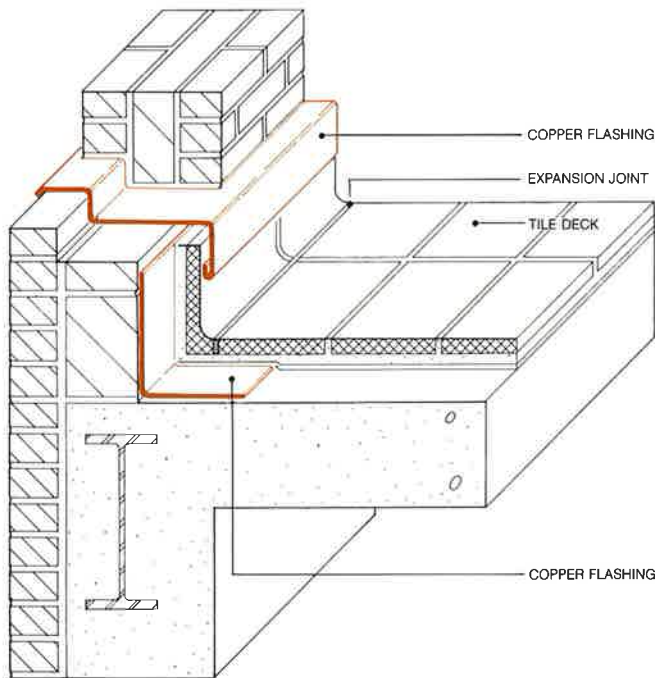

ALTERNATE WITH TILE ROOF DECK

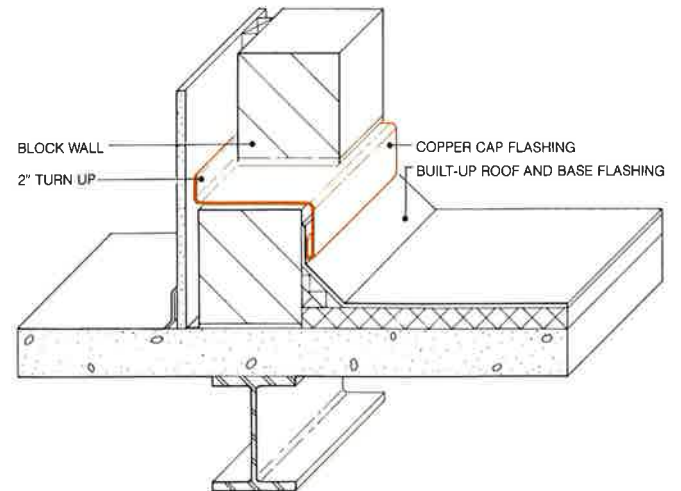

RISING WALL AT ROOF

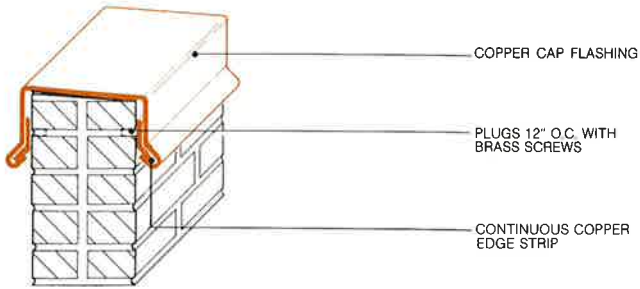

COVER AT HIGH PARAPET

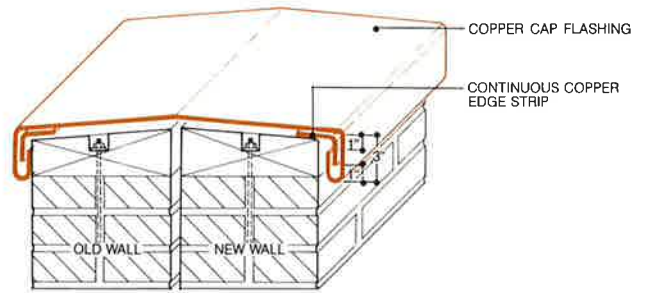

COVER WHERE OLD AND NEW WALLS ARE EQUAL HEIGHT

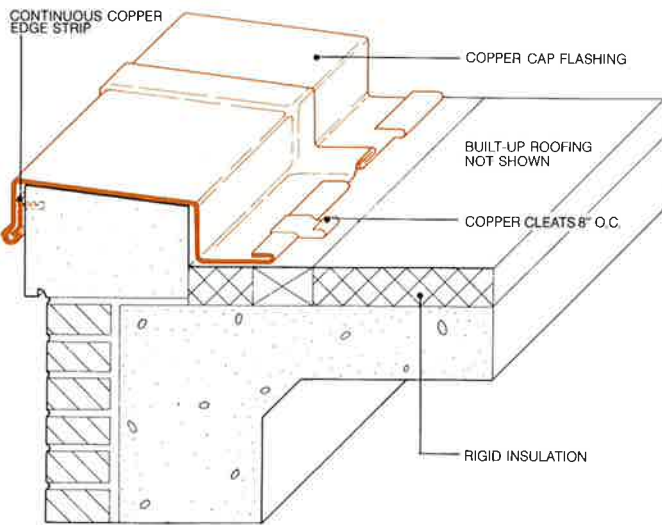

COMPLETE COVER AT ROOF LEVEL

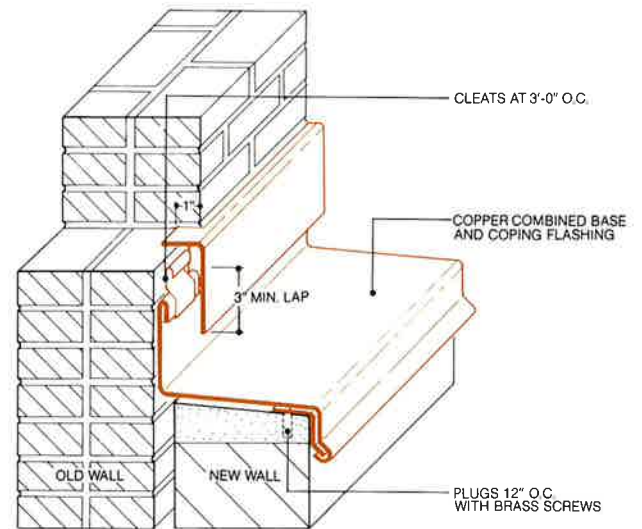

COVER WHERE OLD WALL IS HIGHER THAN NEW WALL

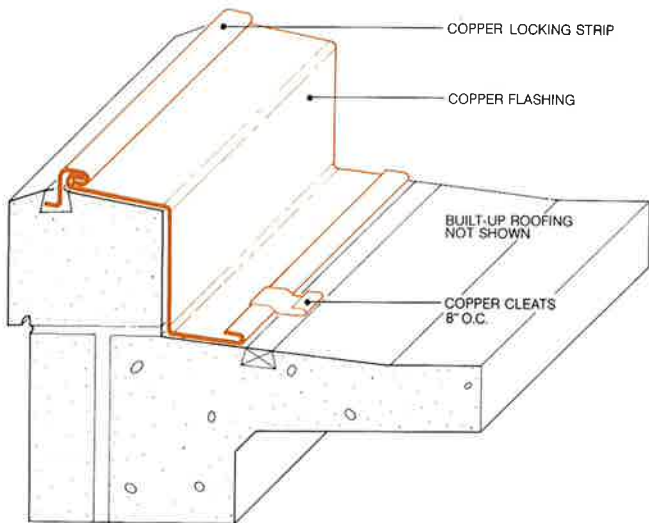

PARTIAL COVER AT ROOF LEVEL

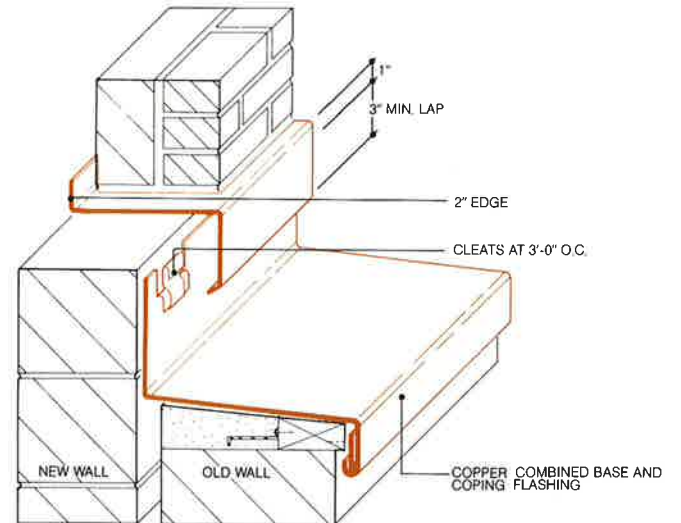

COVER WHERE NEW WALL IS HIGHER THAN OLD WALL

FLASHING AT INTERSECTIONS OF PITCHED ROOFS WITH WALLS

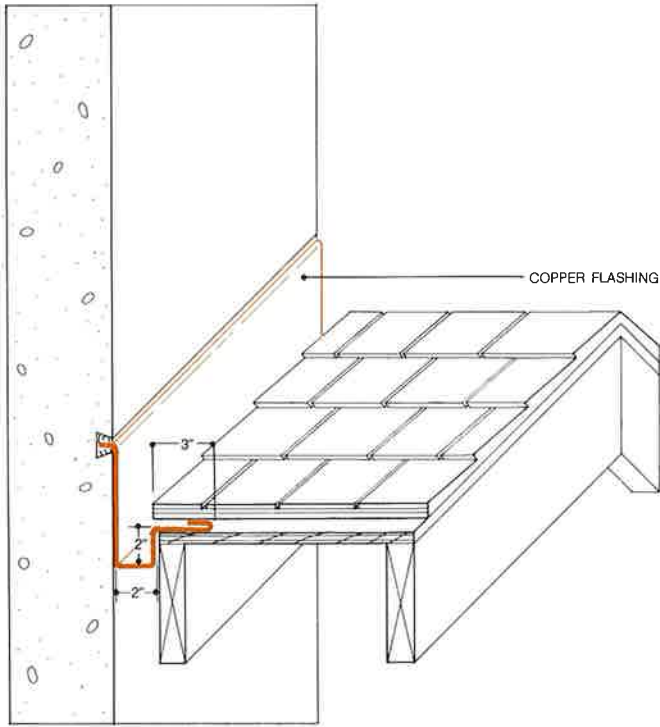

ONE PIECE FLASHING

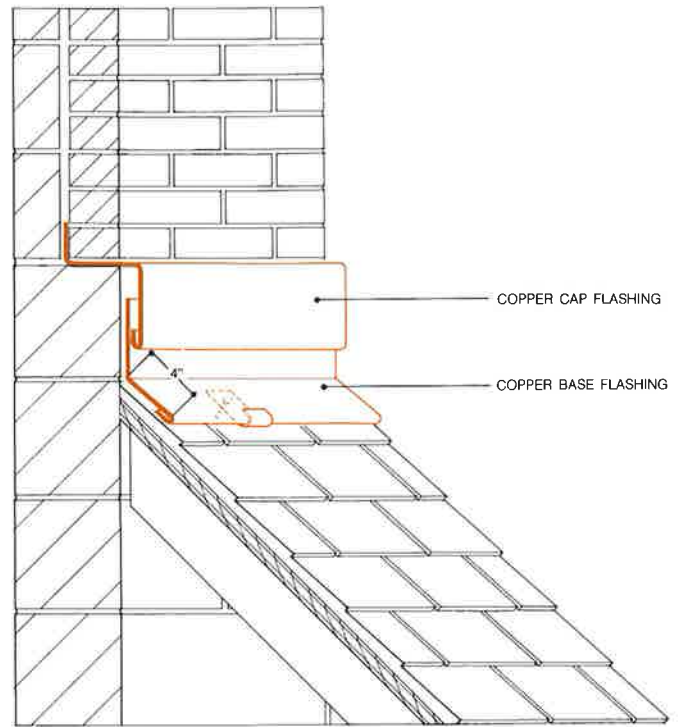

TOP OF SLOPE

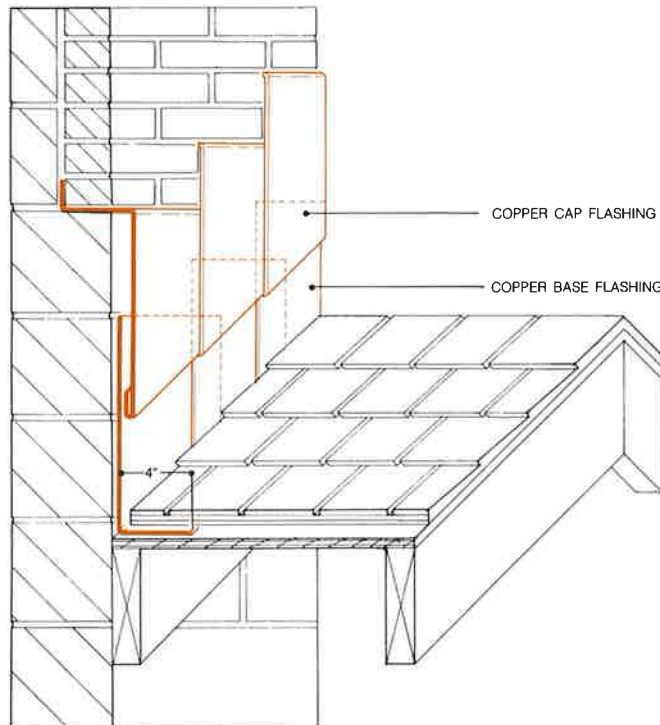

STEPPED CAP AND BASE FLASHING

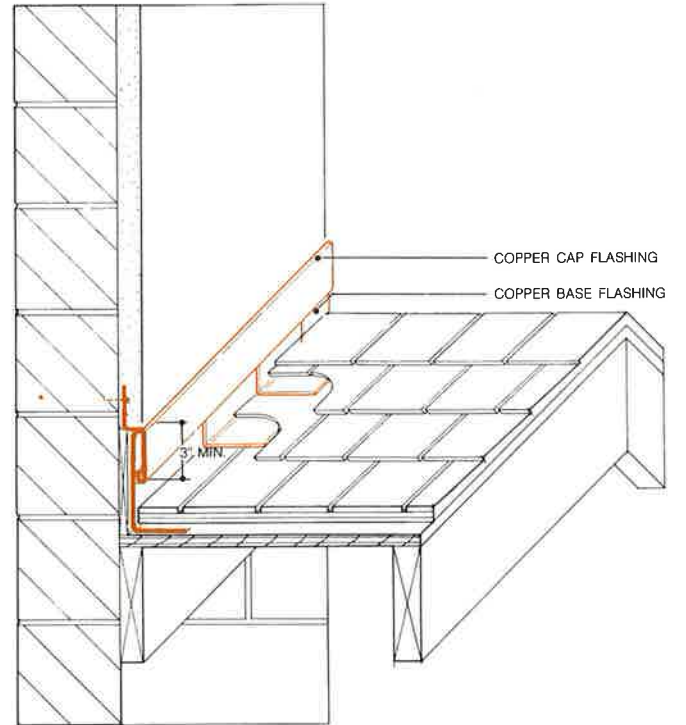

STUCCO WALL FLASHING

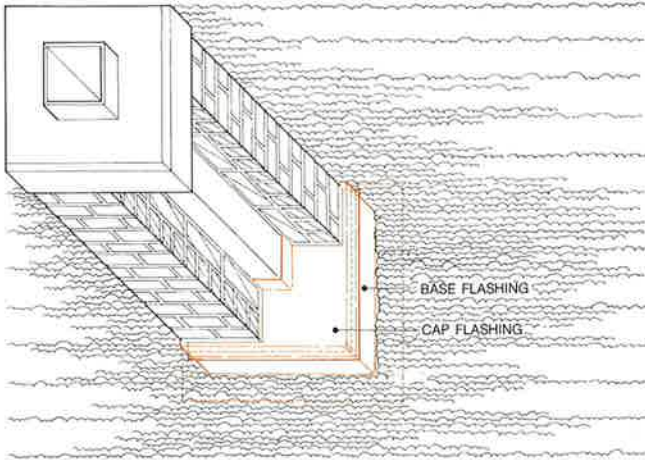

FLAT ROOF

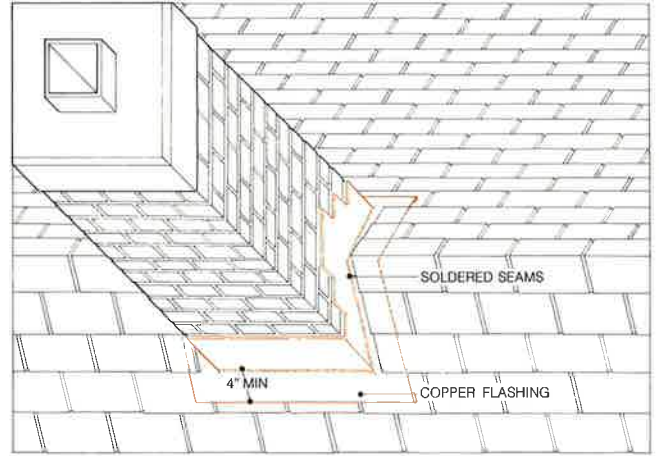

CHIMNEY AT RIDGE

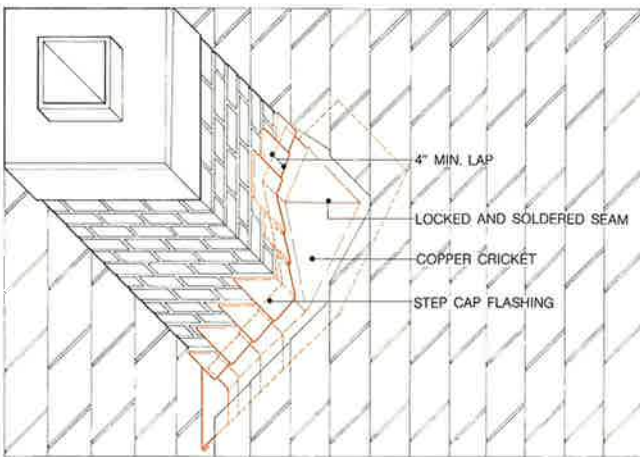

TWO PIECE CHIMNEY CRICKET

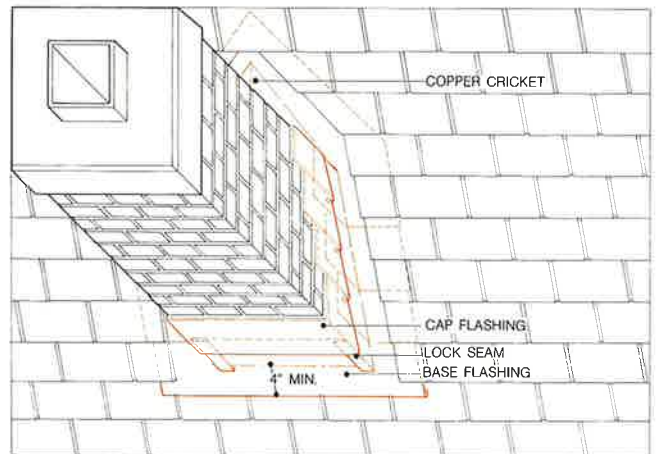

FLASHING AT BASE OF CHIMNEY

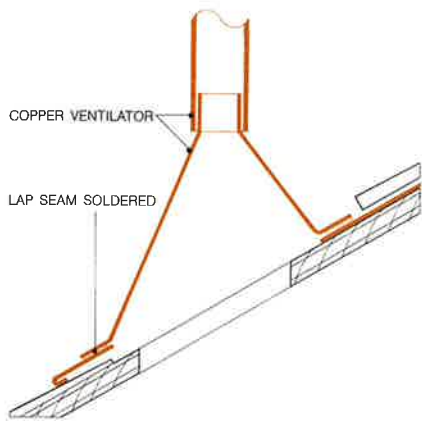

VENTILATOR FLASHING

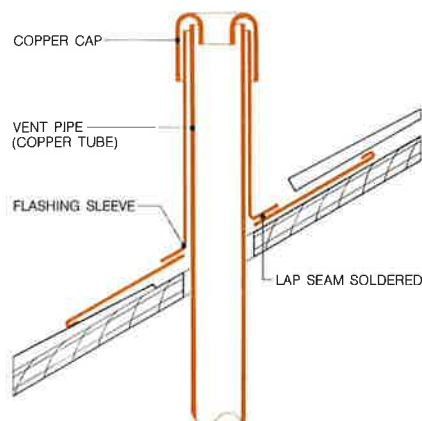

VENT FLASHING

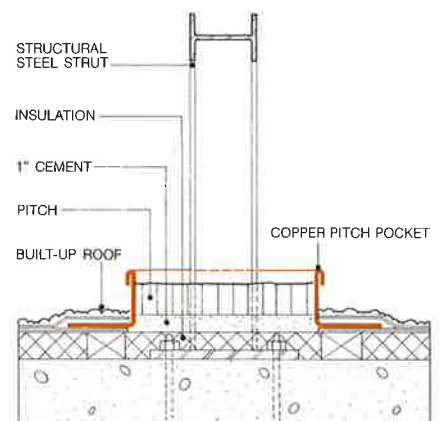

PITCH POCKET DETAIL

RIDGE AND VALLEY FLASHING

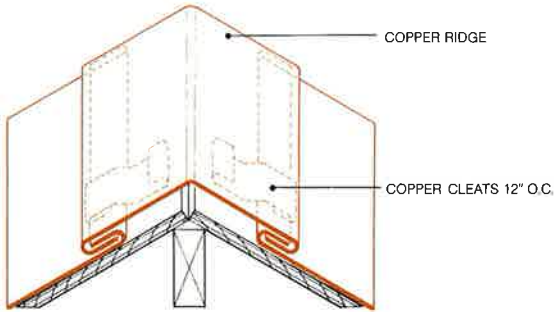

RIDGE AT COPPER ROOF

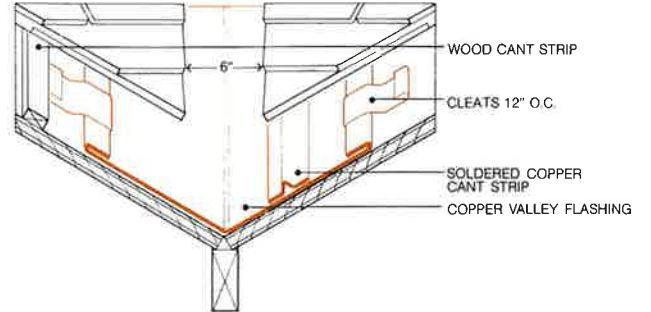

OPEN VALLEY

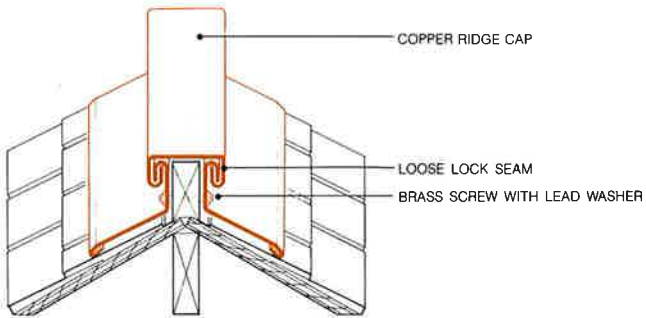

SPRING AND BATTEN RIDGE

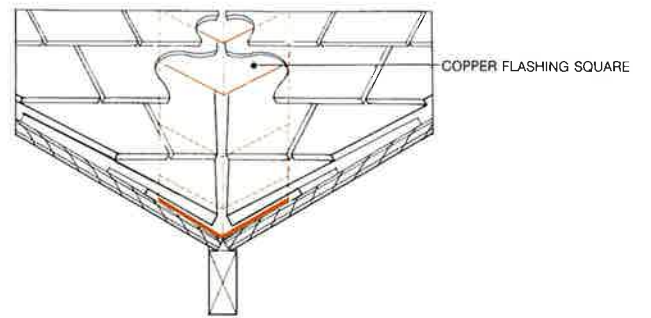

CLOSED VALLEY

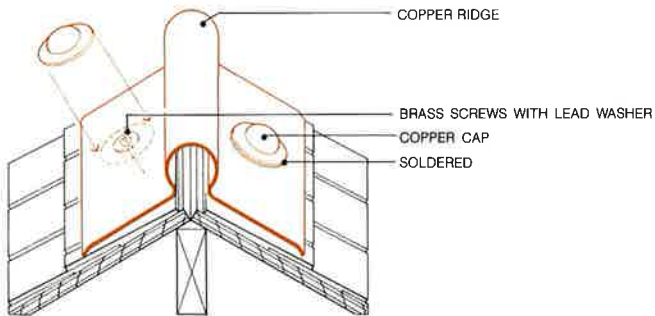

SCREWED DOWN RIDGE

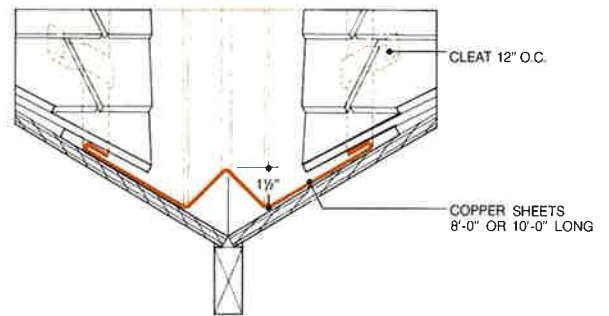

EQUAL SLOPES - UNEQUAL WATER DISTRIBUTION

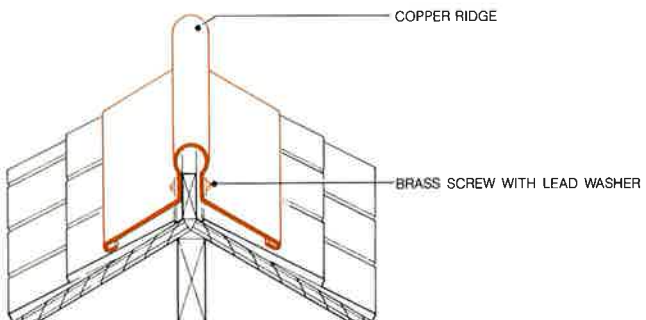

SPRING RIDGE

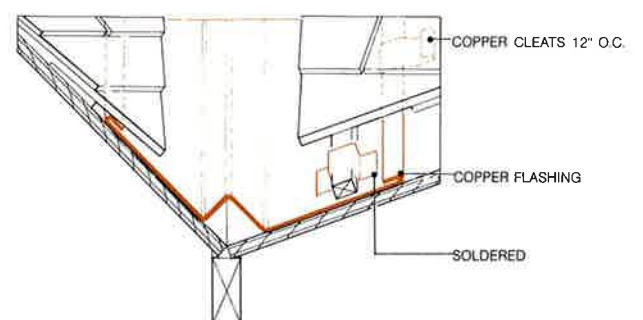

UNEQUAL SLOPES

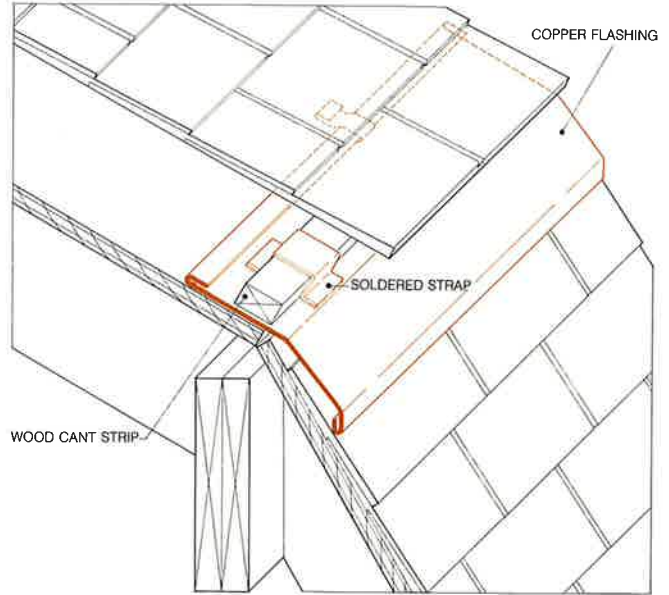
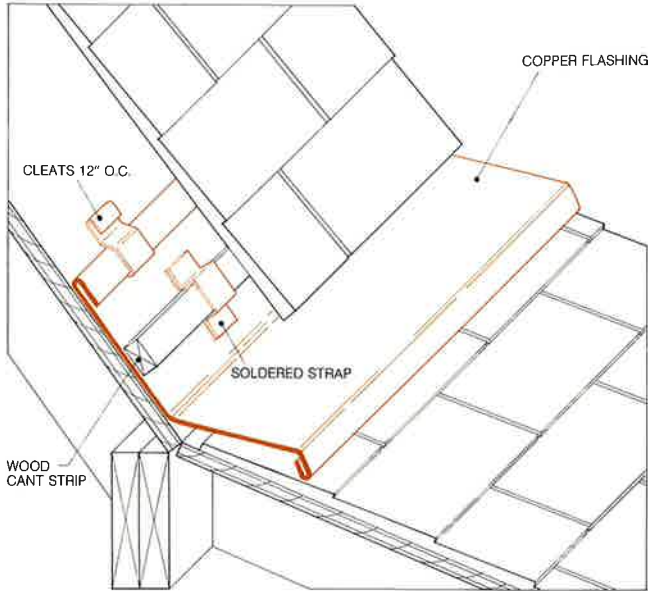

CHANGE OF ROOF SLOPE FLASHING

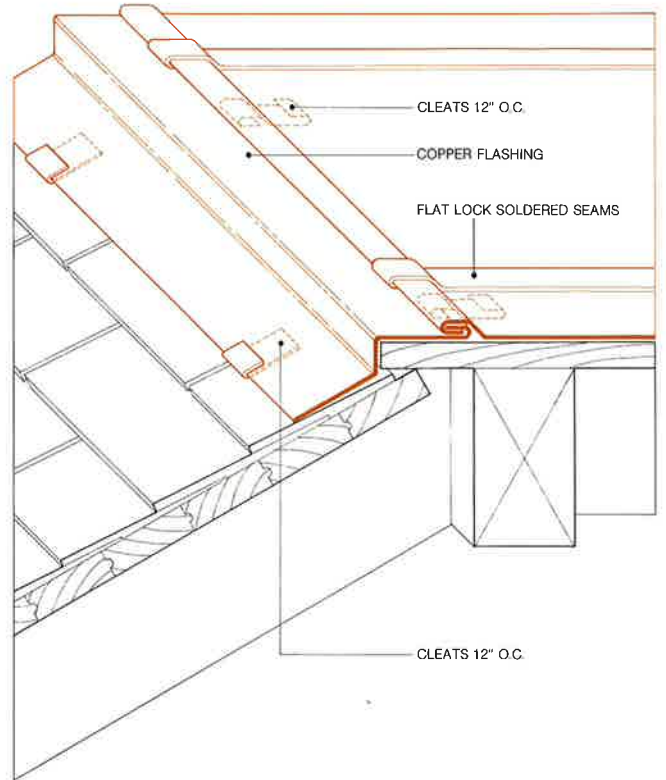
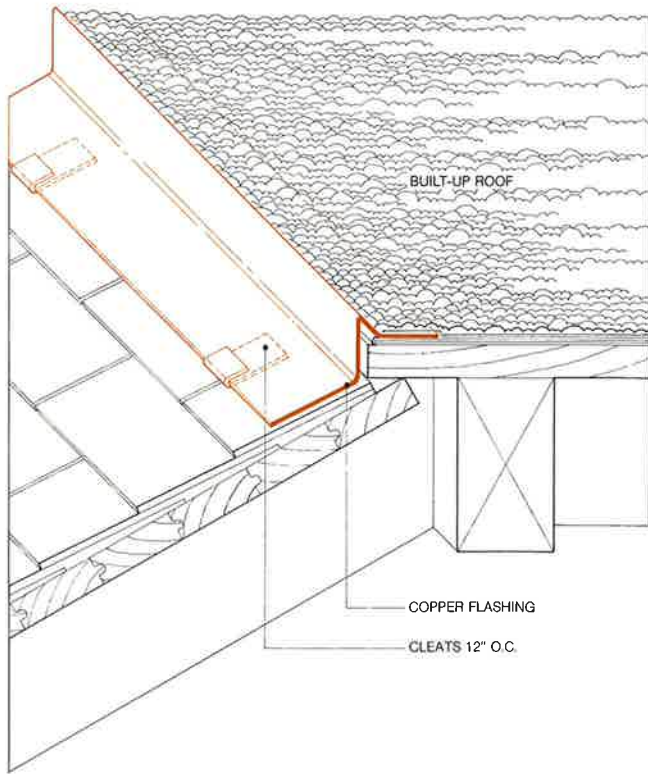

COPPER DECK AND BUILT-UP ROOF ABOVE SHINGLE ROOF

BUILDING EXPANSION JOINT AT ROOF AND WALL WITH PARAPET AT ROOF EDGE AND EXPANSION IN ONE DIRECTION

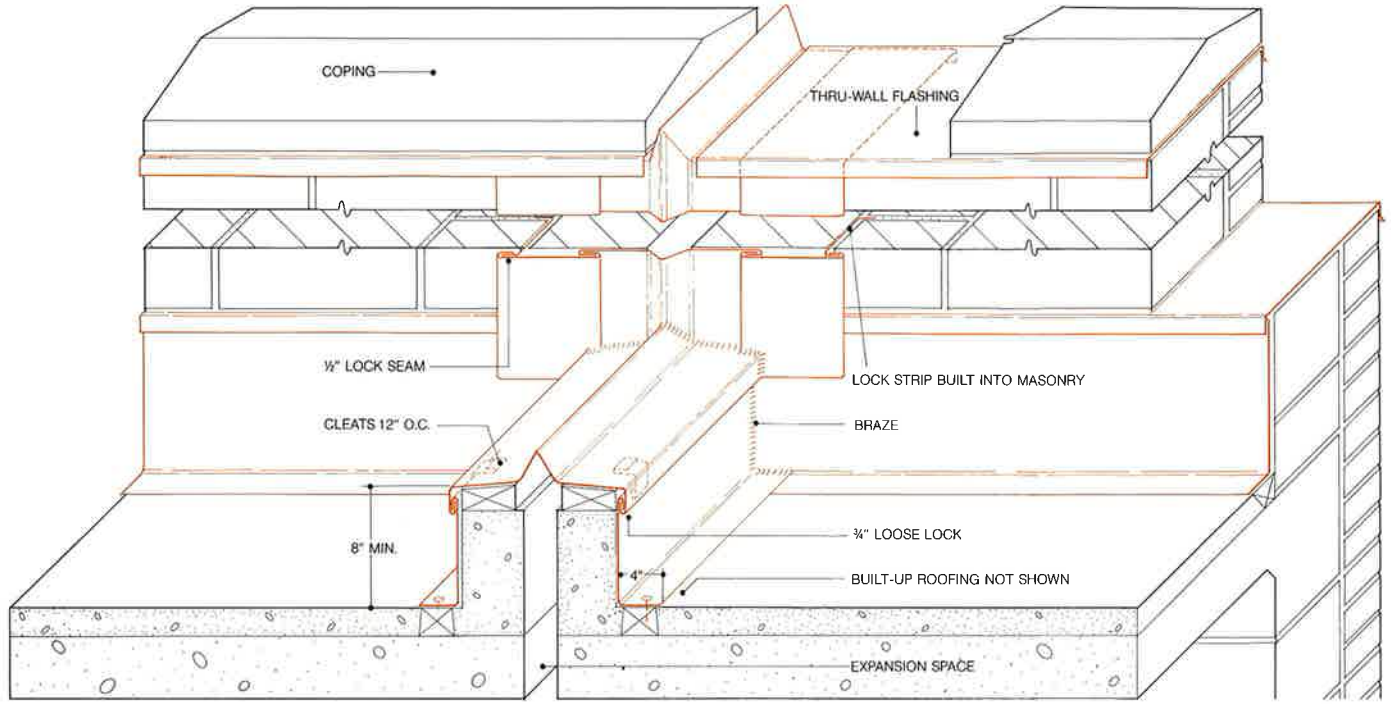

V-TYPE COVER FOR STRUCTURAL EXPANSION JOINT

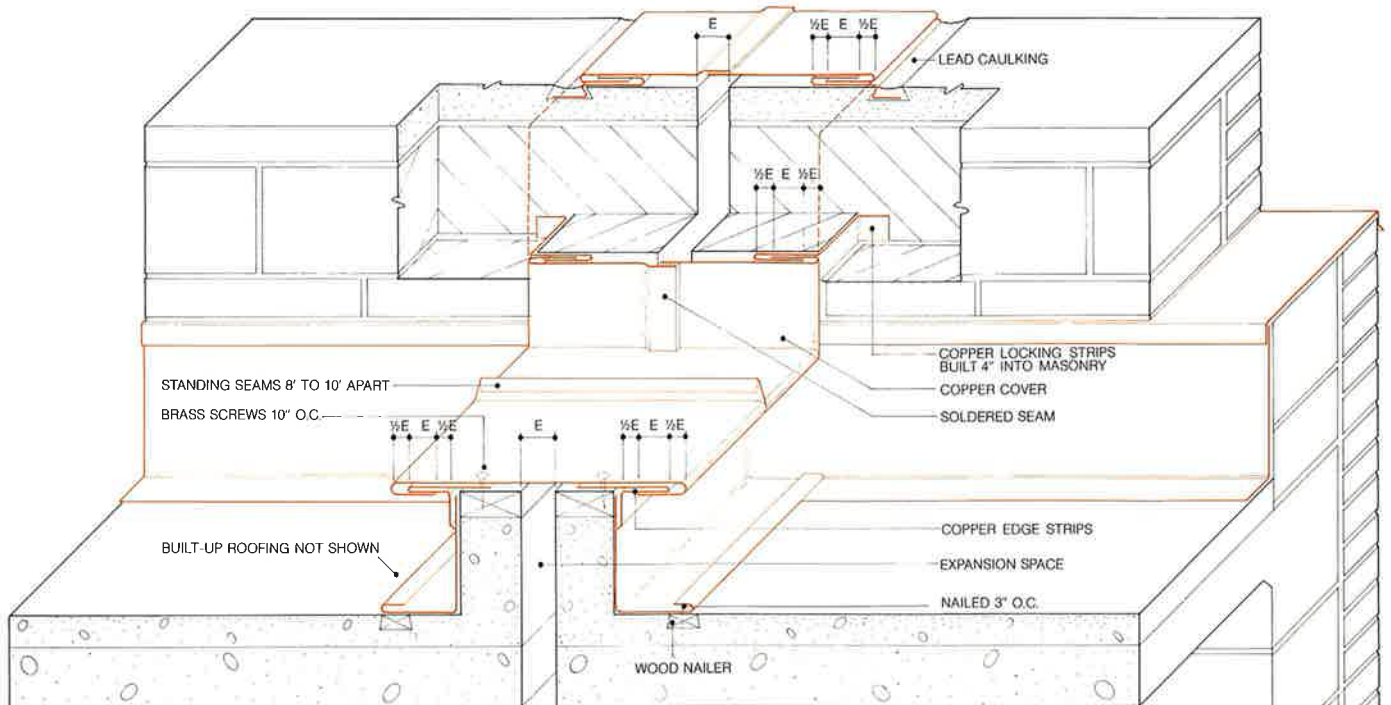

FLAT-TYPE COVER FOR STRUCTURAL EXPANSION JOINT

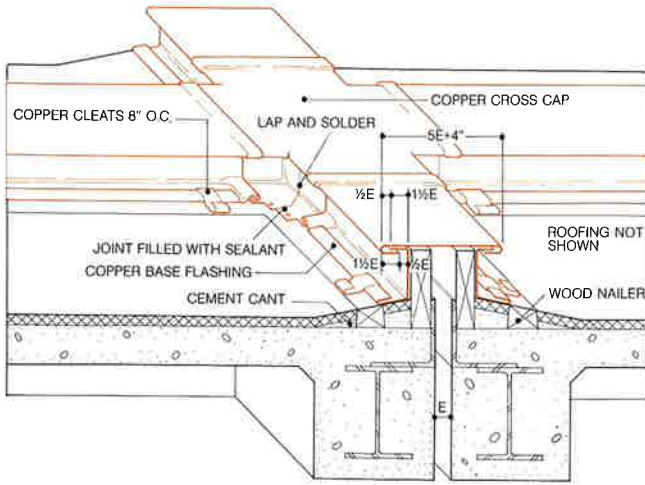

INTERSECTION OF EXPANSION JOINTS

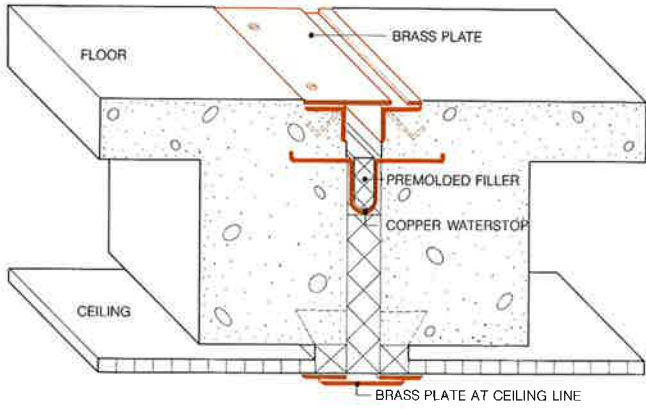

JOINT THRU FLOOR AND CEILING

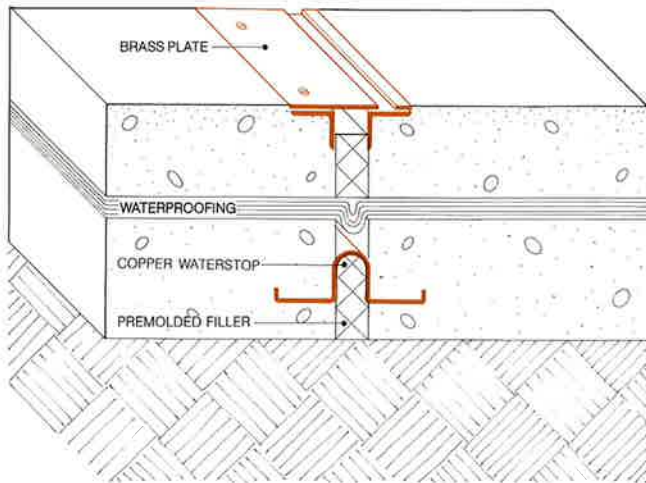

JOINT THRU FLOOR SLAB ON GRADE

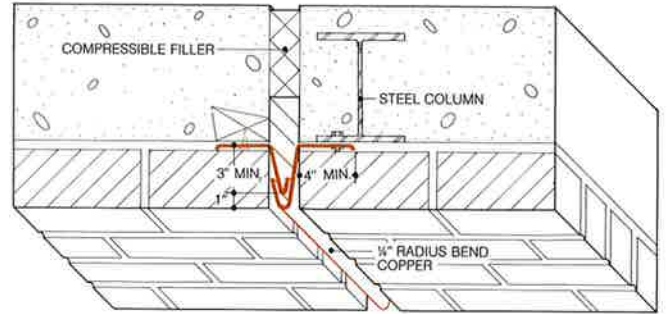

JOINT AT MASONRY WALL

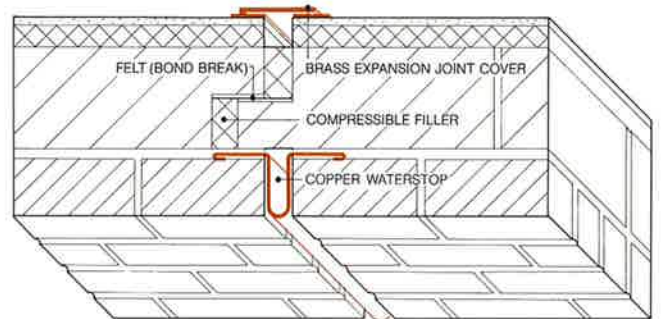

JOINT AT MASONRY WALL

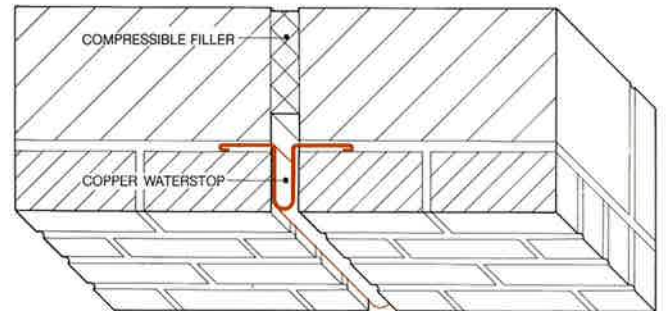

JOINT AT FOUNDATION WALL

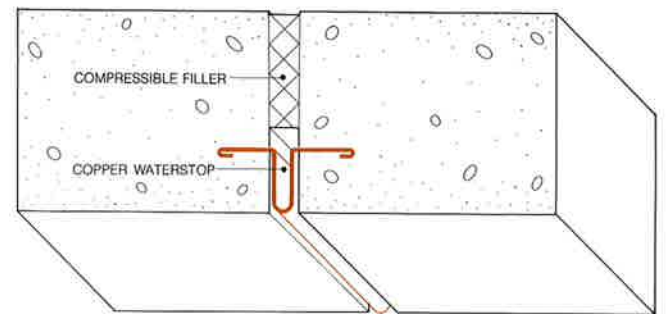

JOINT BELOW GRADE

FLAT SEAM ROOFING

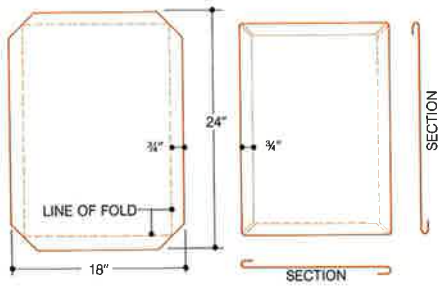

STANDARD ROOFING SQUARE

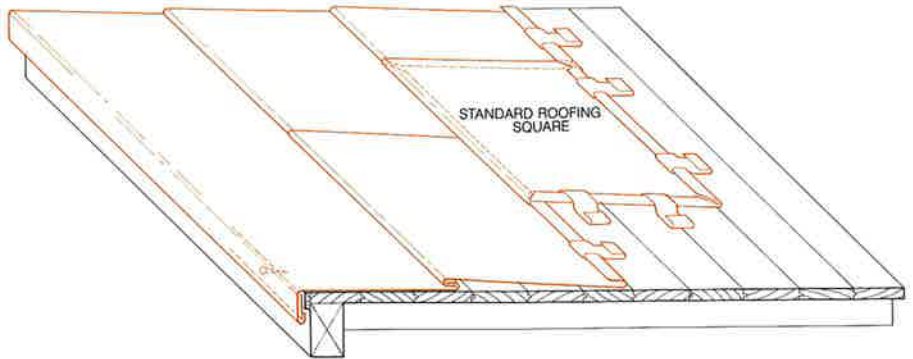

TYPICAL FLAT SEAM ROOF

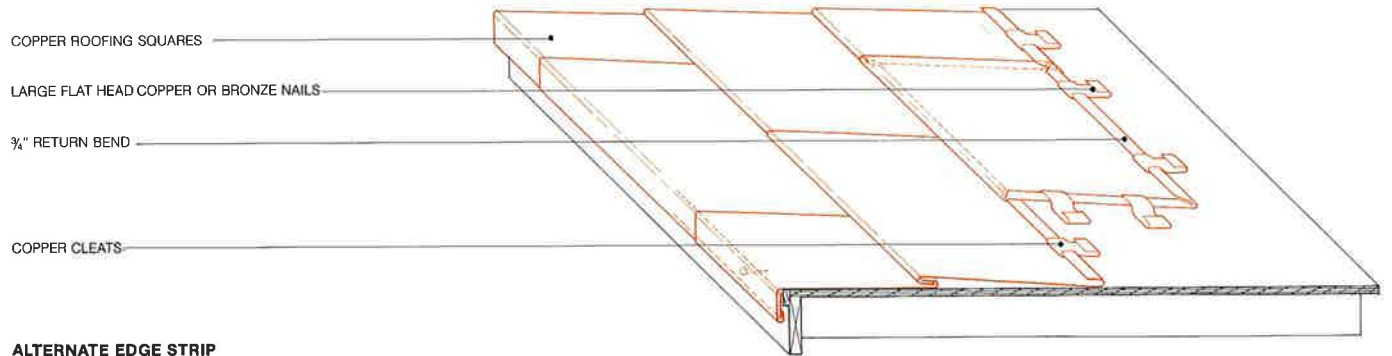

ALTERNATE EDGE STRIP

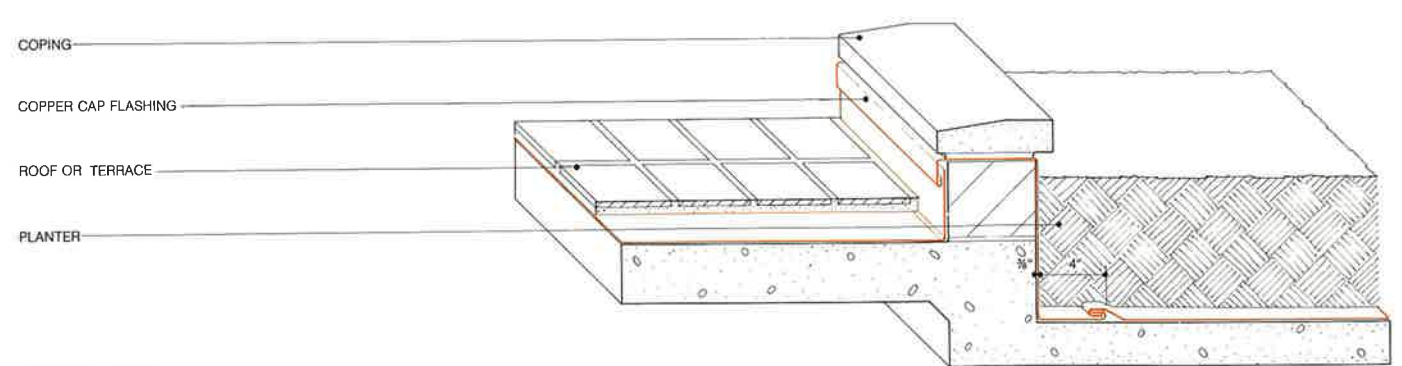

PLANTER DETAIL

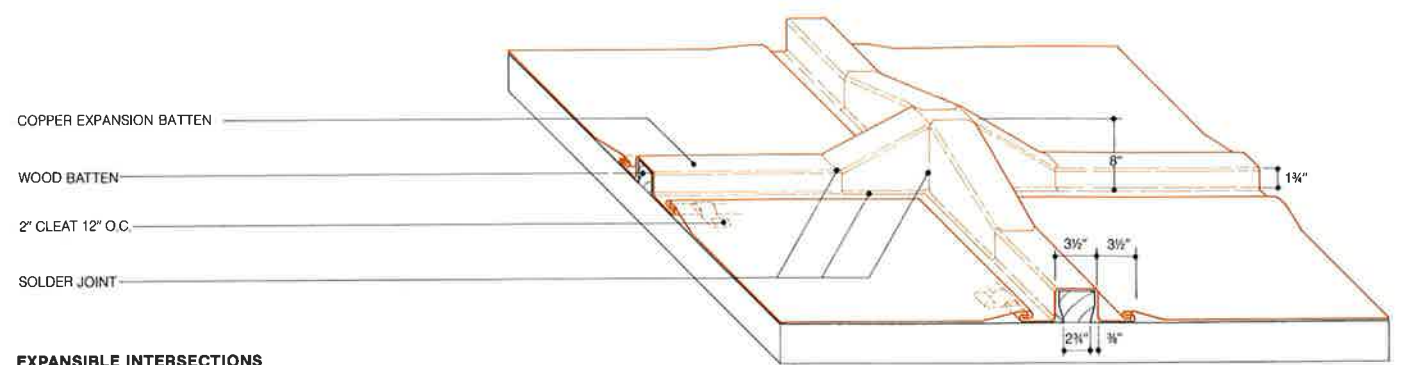

EXPANSIBLE INTERSECTIONS

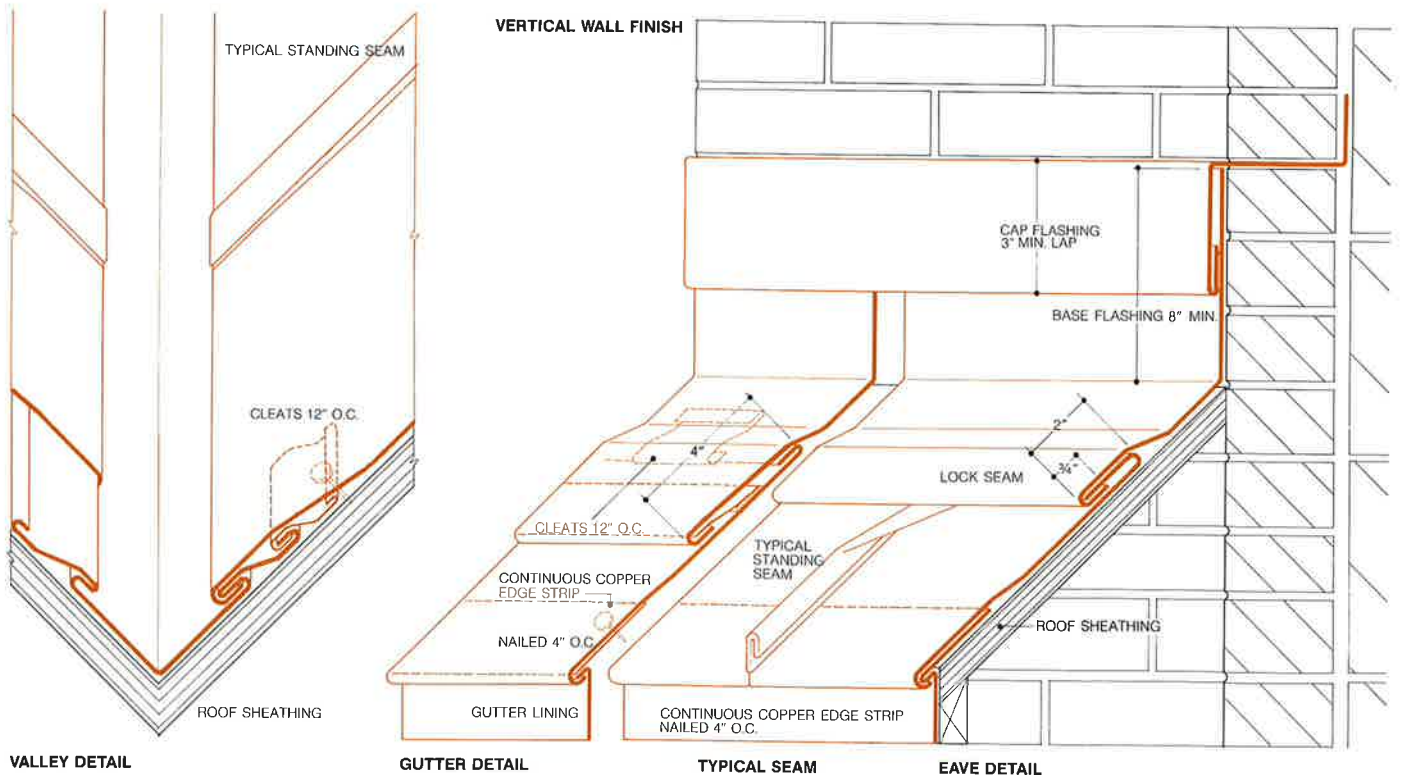
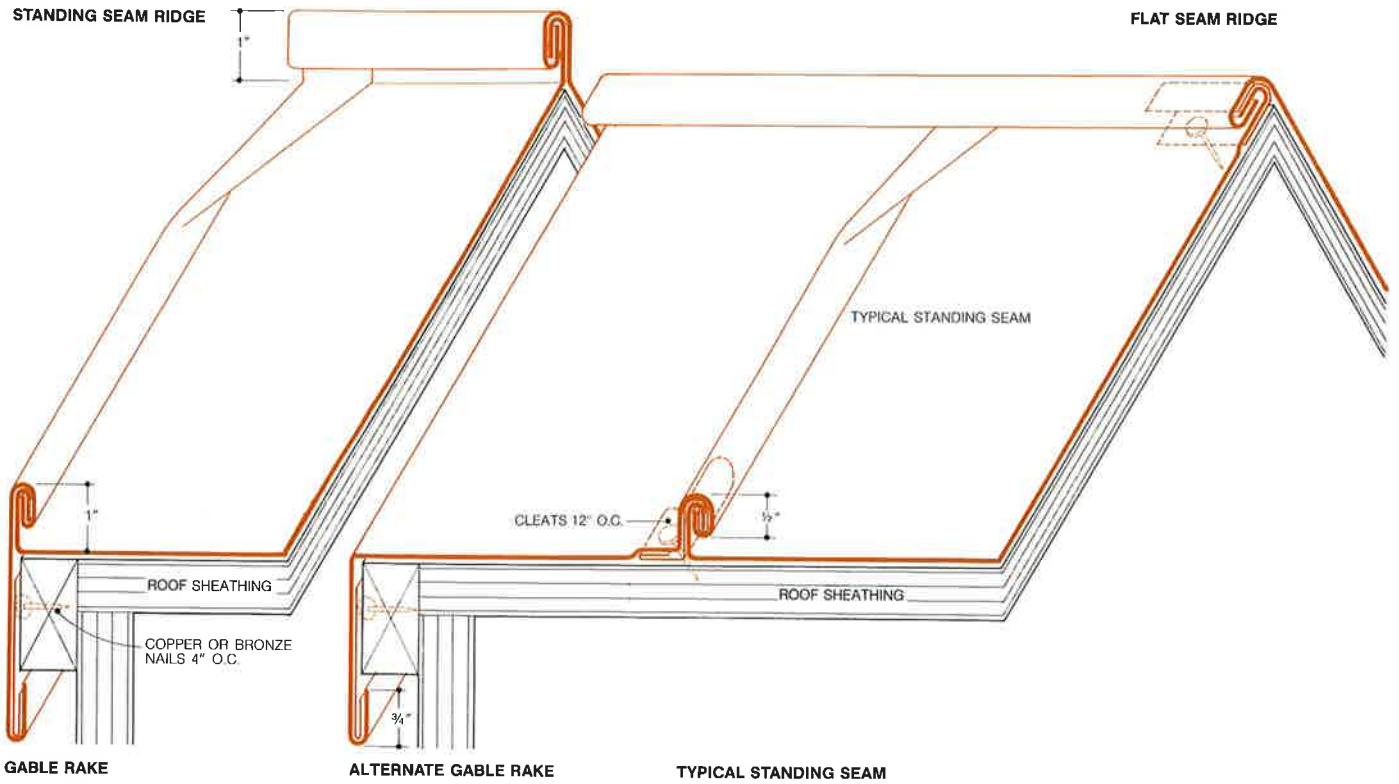

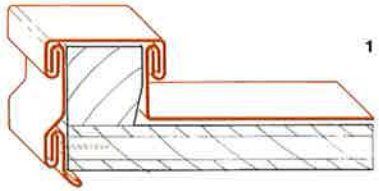

1

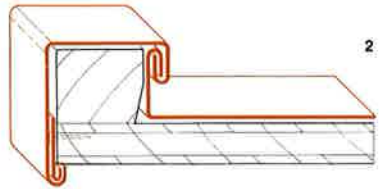

2

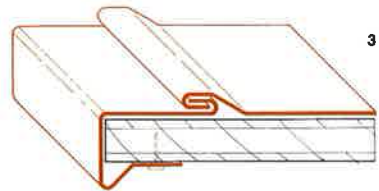

3

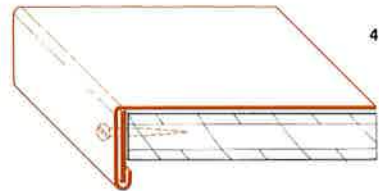

4

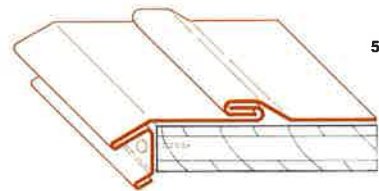

5

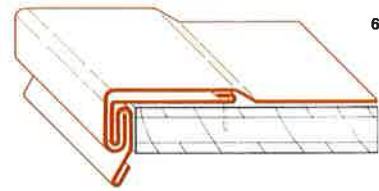

6

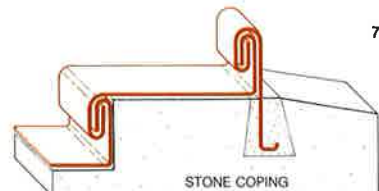

7

GABLE ENDS

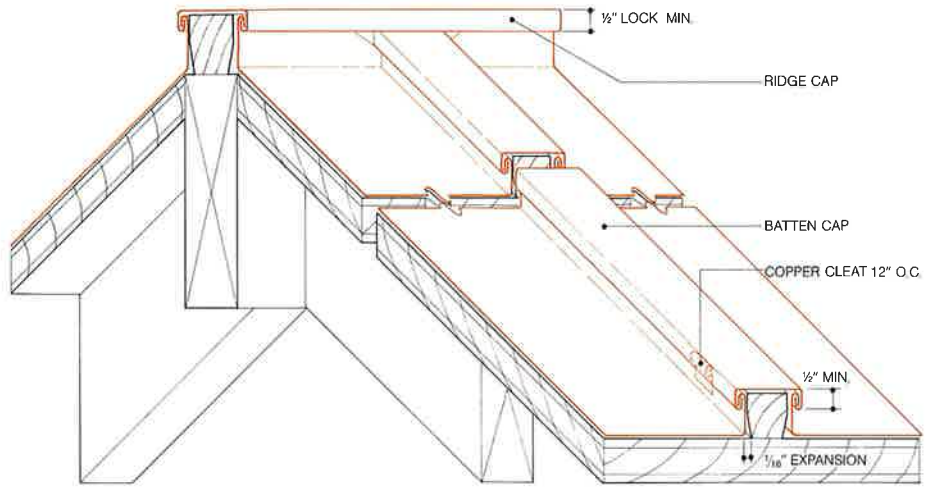

RIDGE AND TYPICAL BATTEN SEAM

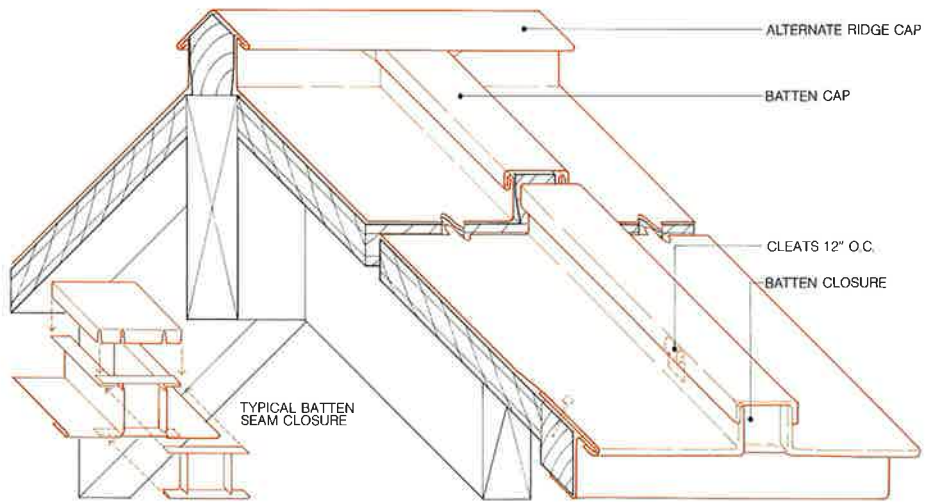

ALTERNATE RIDGE AND BATTEN AT EAVE

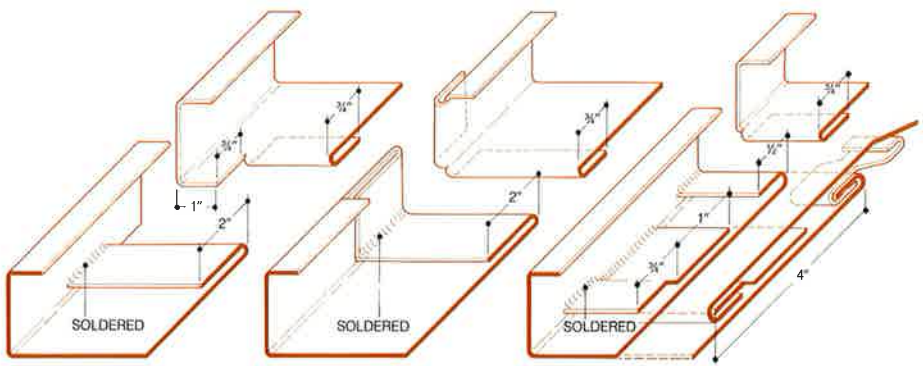

TRANSVERSE SEAMS

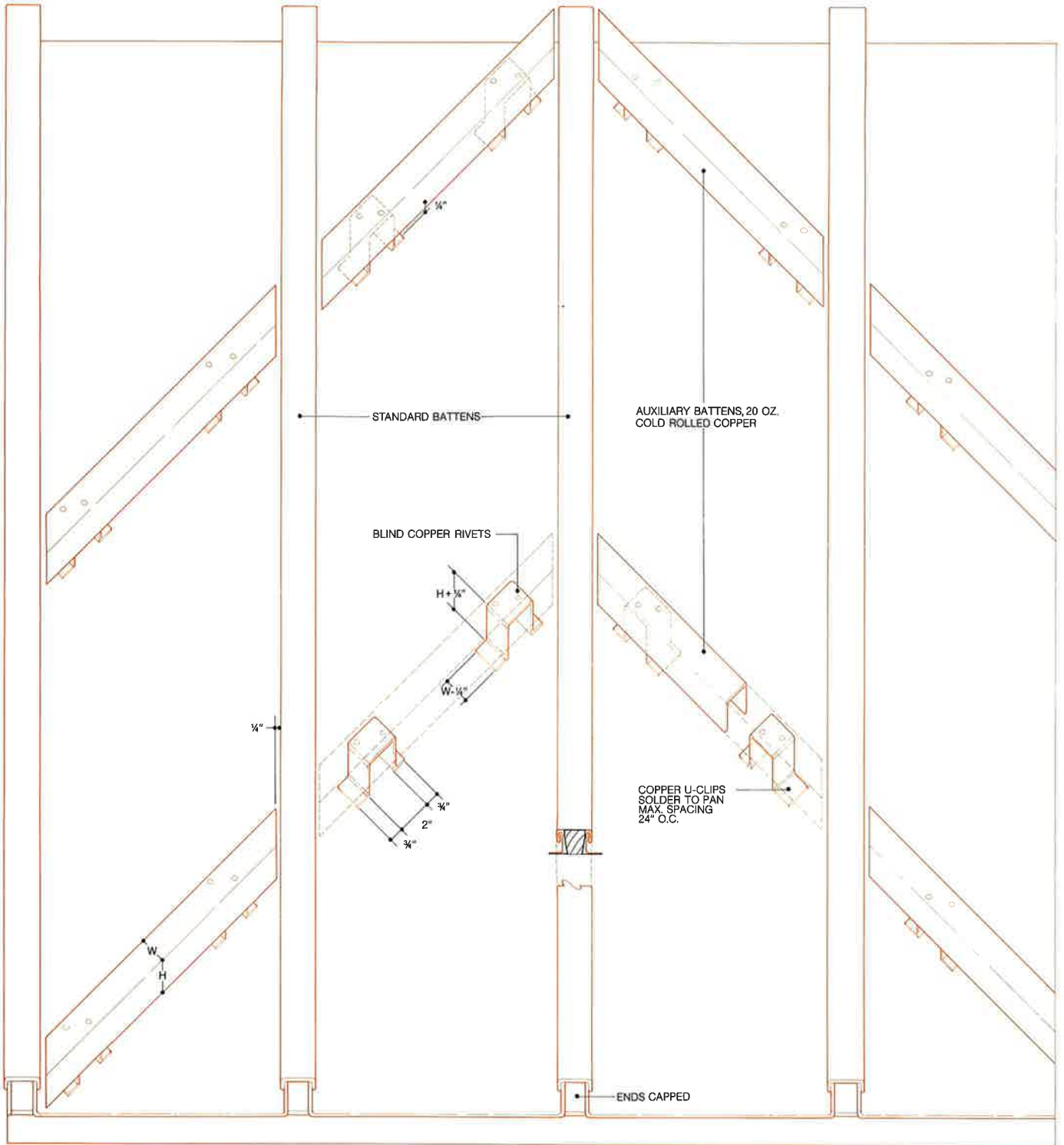

AXONOMETRIC OF ROOF

GUTTERS

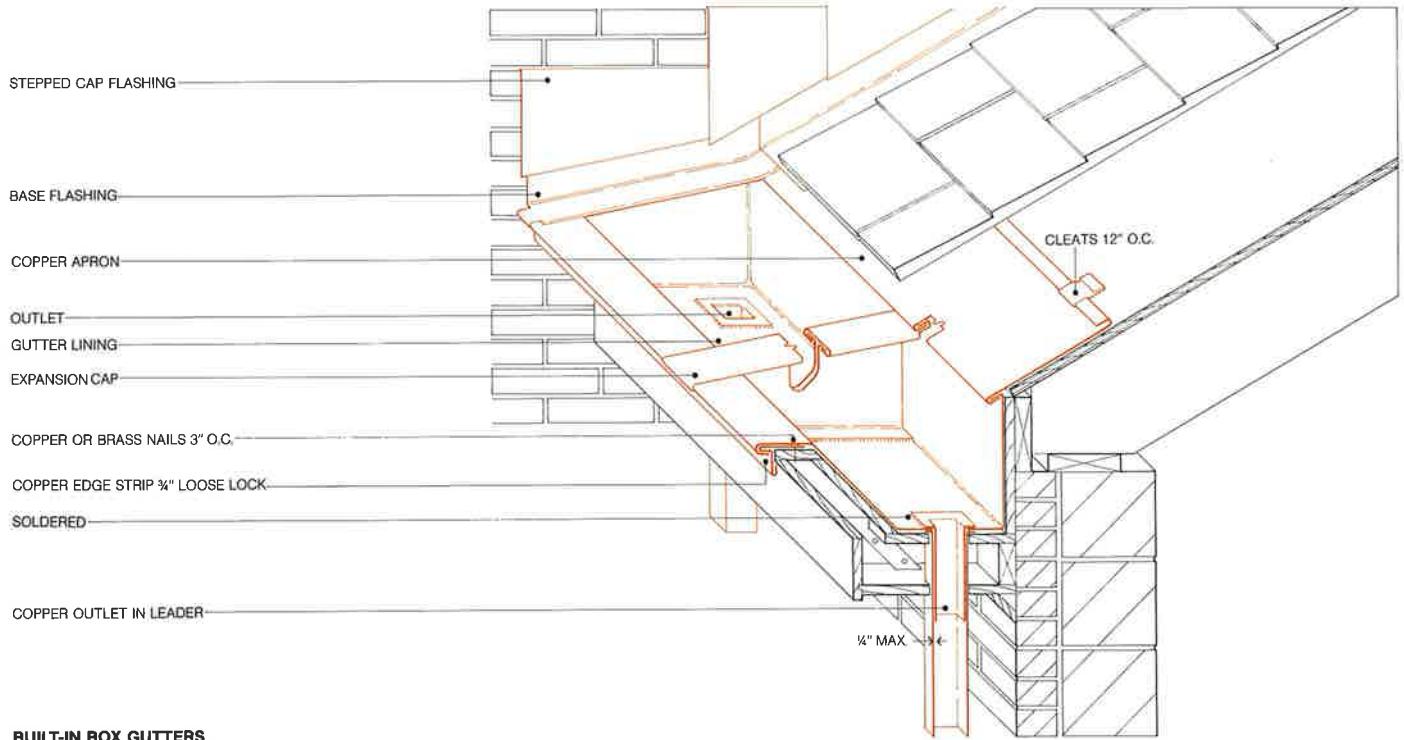

BUILT-IN BOX GUTTERS

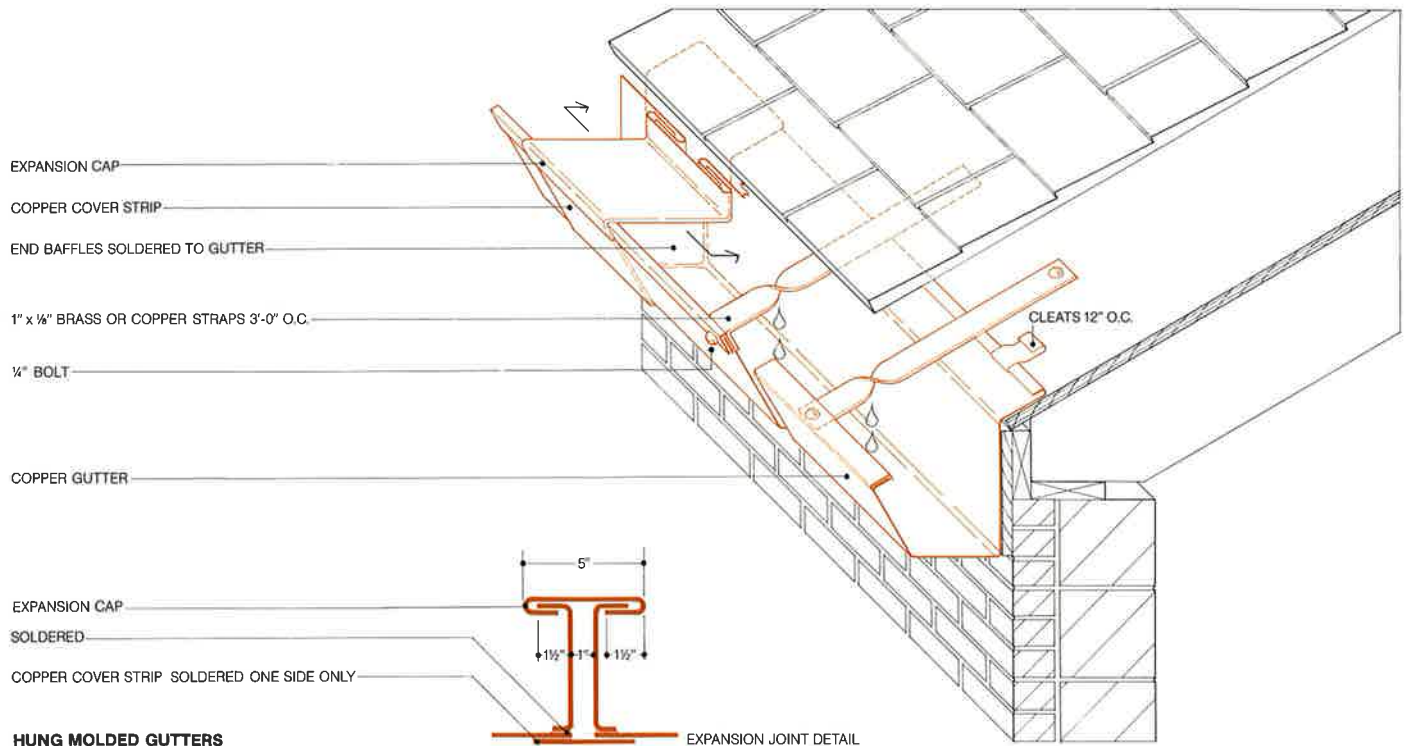

HUNG MOLDED GUTTERS

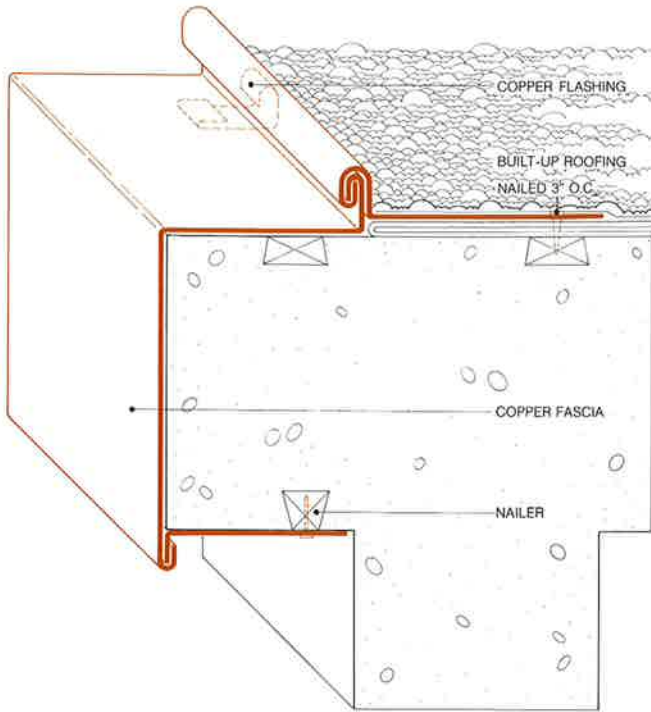

FASCIA WITH SET-BACK GRAVEL STOP

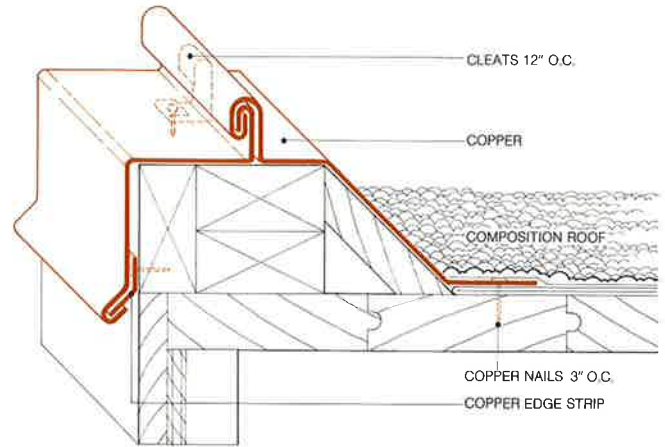

SET-BACK GRAVEL STOP AT FASCIA BOARD

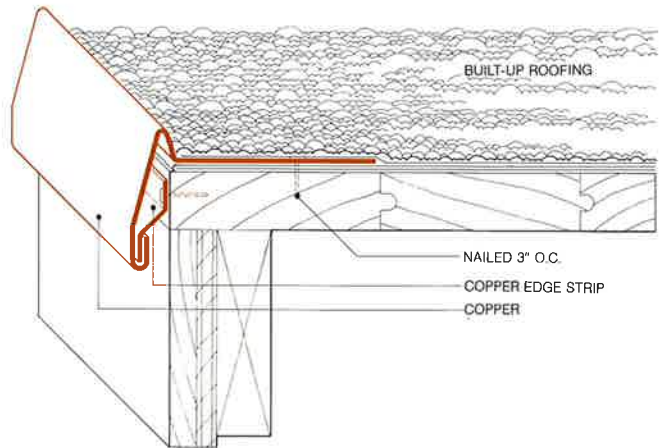

GRAVEL STOP AT WOOD PLANK ROOF

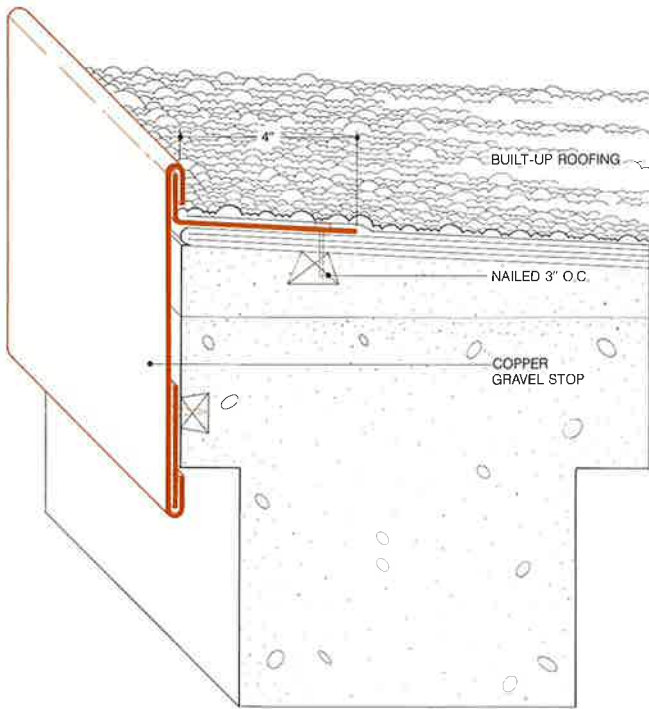

DEEP COPPER FASCIA

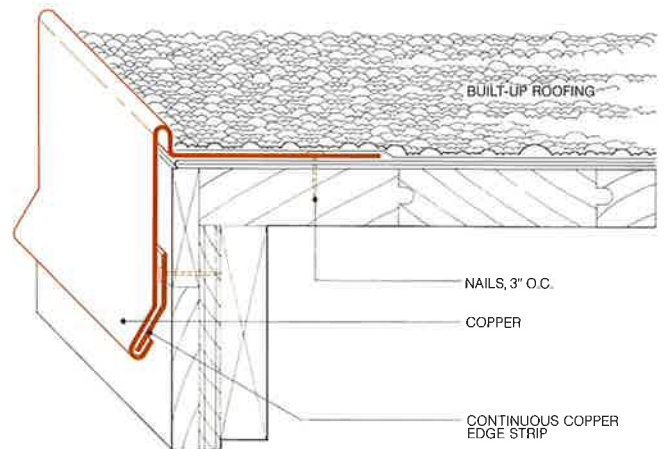

GRAVEL STOP AT FASCIA BOARD

SHEET COPPER SPECIFICATIONS

1. GENERAL

The work of this Section shall be performed in accordance with the requirements of the Contract Documents. *COMMENT: Refer to Contract Documents which include Agreement, General Conditions and Supplementary General Conditions to alert subcontractor to all contract requirements.*

2. SCOPE

The work required under this Section includes the furnishing of all labor and material required to complete all sheet metal work and related items indicated on drawings and described herein. *COMMENT: Specifier may elect to provide a more detailed scope of work by listing specific items of sheet metal and related items to be included in the Contract.*

3. WORK OF OTHER SECTIONS

The following items are specified under other Sections of these Specifications. *COMMENT: Specifier should list here items of sheet metal work normally included under this section but which are specified under other sections for a specific project.*

4. MATERIALS

a. Sheet Copper: ASTM Specification B370, cold rolled temper, weighing not less than 16 ounces per sq. ft. unless otherwise specified.

COMMENT: Specify 16 ounce copper under this paragraph with exceptions specified hereinafter.

b. Lead-Coated Copper: ASTM Specification B101, (Type I) (Type II), Class A, and of weight and temper as hereinafter specified for specific locations, or as shown on drawings.

COMMENT: Select either Type I or Type II. Type I refers to lead coating applied by hot-dipping, Type II by electro-deposition; Class A coating weighs 12 to 15 pounds per 100 square feet. The weight of lead coating is the total weight applied to two sides of 100 square feet of copper sheet with approximately one half of the coating on each side.

c. Nails and Fasteners including rivets, screws and bolts shall be of hard copper, brass, or bronze.

1. Nails for wood and nailing concrete shall be flathead, barbed, wire slating nails, not less than No. 12 gauge, 1" long.

2. Screws and bolts shall have round heads.

3. Expansion shields shall be lead sleeves.

COMMENT: See page 8 for description of nails and fasteners.

d. Solder: ASTM Specification B-32, composition 50% tin and 50% lead. 60/40 for lead coated copper.

COMMENT: See pages 8 and 53 for solder.

e. Flux: Rosin, muriatic acid neutralized with zinc or approved equal.

f. Roofing Felt: Asphalt or coal tar saturated felt weighing not less than 15 pounds per 100 square feet.

g. Building Paper: Rosin sized, unsaturated paper weighing approximately 6 pounds per 100 square feet.

h. Reglets:

1. Open type reglets, formed of copper approximately $\frac{3}{4}$ " deep with a minimum $\frac{1}{4}$ " opening.

2. Friction type reglets, formed of copper with anchoring flanges having a receiving slot approximately $\frac{3}{4}$ " deep.

i. Sealant: Approved type of butyl, polysulfide, silicone, or urethane.

5. SAMPLES

Submit the following samples in accordance with the Contract requirements for the Architect's approval. Obtain approval before delivery or fabrication.

COMMENT: List specific samples required.

6. SHOP DRAWINGS

Submit the following shop drawings for sheet metal work in accordance with the

Contract requirements for the Architect's approval. Indicate thickness and dimensions of all other parts, fastenings and anchoring methods, expansion joints and other pertinent information.

COMMENT: List specific shop drawings required.

7. GENERAL REQUIREMENTS

a. Cleats: 2" wide by 3" long copper, spaced not over 12" on center unless otherwise specified. Secure one end with two nails and fold back over nail heads. Lock free end of cleat into seam or into folded edge of copper sheet.

COMMENT: See page 8 for illustration of cleats.

b. Tinning: Tin edges of plain copper sheets to be soldered for a width of $1\frac{1}{2}$ " both sides with solder. Tinning of lead-coated copper is not required prior to soldering; however, wire brush lead in contact with solder to produce a bright surface.

c. Soldering: Perform slowly with well-heated coppers, so as to heat thoroughly the seam and sweat the solder through its full width. When soldering lead-coated copper, brush a liberal amount of flux into the seam.

d. Edge and Drip Strips: Provide where sheet metal extends over edges and where necessary to secure sheet metal work at eaves, gables, rakes, and elsewhere. Form edge strips of $1\frac{1}{4}$ " x $\frac{1}{8}$ " brass strip or 20 ounce copper sheet. Secure to building construction with brass screws spaced not over 12" on centers. Where fastening is made in masonry or concrete, use lead sleeves to receive screws. Install strips in continuous, butted long lengths to allow metalwork to be hooked over lower edge not less than $\frac{3}{4}$ ". *COMMENT: Double folded 16 ounce copper may be used.*

e. Seams:

1. Standing seams shall finish not less than 1" high unless otherwise specified.

2. Flat-Lock Seams: Finish not less than $\frac{3}{4}$ " wide.

3. Lap seams where soldered: finish not less than 1" wide.

4. Lap seams: Not soldered: Overlap 3" unless otherwise noted.

5. Seams: Make in direction of flow.

COMMENT: See page 9 for illustration of seams.

f. Dissimilar Metals. Place sheet lead between copper and iron, or steel, or paint the mating surfaces of copper and aluminum, iron or steel with asphaltum paint.

COMMENT: See pages 6 and 52 for discussion of galvanic corrosion.

g. Reglets of the open or friction type: Use in concrete or where shown to receive flashing. Nail reglets to wood forms with double headed nails.

1. **open slot reglets:** Turn sheet metal into open slot reglets and secure with lead or copper plugs about 12" apart and fill with sealant.

2. **friction type reglets:** Turn sheet metal into friction type reglets in exposed locations and secure by indenting slot 12" on center with a dull punch.

COMMENT: See pages 31, 33, and 38 for illustrations of reglets.

8. PREPARATION OF SURFACES

Surfaces to which sheet metal is to be applied shall be smooth, sound, clean, dry and free from defects that might affect the application.

Apply a layer of roofing felt followed by a layer of building paper to surfaces receiving copper roofing, valleys and gutter linings. Lap each ply 2" with the slope and nail with large flathead copper nails.

COMMENT: See page 6 for discussion of preparation of surfaces and use of roofing felt and building paper.

9. FLASHING

a. General: Flash intersections of roofs with vertical surfaces, openings in roof (and wall) surfaces and projections

otherwise shown or specified, the method of flashing shall be base and cap flashing.

Lap cap flashing over base flashing at least 3".

1. Continuous flashing: Use where the design or construction is such that base and cap flashing is not feasible. Make continuous flashing in two pieces; with flat-lock seams; filled with sealant.

b. Base Flashing

1. Make base flashings using 8'-0" long sheets, formed into units not more than 24'-0"; join with $\frac{3}{4}$ " flat-locked soldered seams. Join units together with a 3" loose-locked seam filled with sealant.

Straight runs of less than 24'-0" shall have a similar loose-locked seam at the center. A similar loose-locked seam shall occur not more than 8'-0" from any corner.

2. On built-up roofing, extend flashing up vertical surfaces not less than 8", unless otherwise shown, and 4" horizontally out on the roof.

COMMENT: Recommend that two plies of felt flashing be placed over horizontal leg of base flashing cemented with cold mastic.

3. Coat horizontal leg in contact with built-up roofing with asphaltum paint before placing, and secure outer edge by copper nails spaced not over 3" on center.

c. Cap Flashing

1. Use cap or counter flashing on vertical surfaces in conjunction with base flashing and lap base flashings a minimum of 3". Turn bottom edge $\frac{1}{2}$ " back under itself. Crease center of exposed surface longitudinally to produce a spring action that will hold bottom edge against base flashing.

COMMENT: While soft temper copper may be used for cap flashings, such use is discouraged because it may be used inadvertently in other critical areas.

2. Make cap flashing in 8'-0" or 10'-0" lengths. Lap adjoining sheets 3" or join by a hook seam.

3. In masonry walls, build cap flashing into masonry joint at least 2" with inner edge turned up $\frac{1}{4}$ ". In existing walls, rake out joints 1" deep; insert sheets therein and secure with lead caulking rope.

COMMENT: Strike out inappropriate references.

4. In concrete walls, turn cap flashing into a metal reglet and secure therein as previously specified.

COMMENT: Strike out inappropriate references.

d. Through-Wall Flashing

1. Install through-wall flashing where shown on drawings and at the following locations:

(a) Under parapet copings

(b) Under window sills

(c) Over window heads

(d) Over openings in exterior walls

COMMENT: Modify subparagraphs to suit project.

2. Flashings in masonry walls shall be preformed with corrugations, ribs, ridges, or crimps approximately 3/16" high spaced not more than 3" apart. Form deformations to permit free drainage and to prevent lateral movement in two directions. Use one piece flashing at corners. Use 10 ounce copper for flashing entirely concealed in masonry.

COMMENT: Deformed flashings serve two purposes in a mortar joint. They interlock with mortar to prevent movement and do not create a shear plane.

3. Interlock end joints by overlapping corrugations or ribs a minimum of 1 $\frac{1}{2}$ ". Form watertight joint by bedding lap in sealant.

COMMENT: Where mechanically interlocking flashings are used, sealant may be omitted.

4. Set flashing with a bed of mortar below and above as the masonry work progresses. Where dowels puncture metal, cover with copper caps soldered in place.

5. Extend flashings full thickness of wall, to within $\frac{1}{2}$ " of exterior face with edge bent up $\frac{1}{4}$ " to roof side of wall and form $\frac{1}{2}$ " drip.

6. Turn flashings that form cap flashings down face of wall at least 4" and overlap base flashings at least 3".

7. If a proprietary through-wall flashing is approved, install in accordance with manufacturer's specifications.

e. Valley Flashing (for Shingle and Tile Roofing)

1. Open Valley Flashings. Use copper sheets in lengths not exceeding 10'-0". With wood and asphalt shingles, use 16 ounce copper; with slate or tile roofing, 24 ounce copper. Extend valley flashing 5" under roof covering with side edges folded 1/2" for cleating. Lap sheets 6" in direction of flow. Nail upper end of each sheet. Secure side edges with copper cleats spaced 24" on centers. Make open portion at top of valley not less than 5" wide and increase in width 1/8" per foot towards eaves. Where intersecting roofs are on different slopes, form an inverted V 1" high in the metal along center line of valley, and increase lap of valley sheets to 8".

2. Closed Valley Flashing. Use separate pieces of copper built in with each course of roofing material. With wood shingles use 16 ounce copper; with slate or tile use 24 ounce copper. Flashing shall be as long as diagonal of shingle at center of valley, and at least 18" wide where roof slope exceeds 6" to the foot and 24" wide where roof slope is less than 6" to the foot. Bottom edge of each piece of flashing shall be 1/2" short of butt line of shingle in the succeeding course. Nail each piece of flashing along upper edge with copper or bronze nails.

COMMENT: See page 36 for details.

f. Stepped Flashing (For Shingle and Tile Roofing Abutting Vertical Surfaces)

1. Cap Flashing at intersection of pitched roofs with vertical surfaces shall be formed of separate pieces built 2" into masonry with rear edge turned up 1/2". Lap steps 3" and turn down 3" over base flashing.

2. Base Flashing shall consist of separate pieces of copper woven in with each course. Extend out on roof 4" and up on wall 4" and under cap flashing. Extend each piece from top edge of shingle to within 1/2" of butt of overlying shingle.

COMMENT: See page 34 for details.

10. BUILDING EXPANSION JOINTS

a. Roofs: Form expansion joints as detailed using 20 ounce copper. Provide covers in sections not over 8'-0" long with loose-locked seams filled with sealant. Fit joints closely, form them to be watertight and with provision for expansion and contraction.

b. Exterior Walls: Fold expansion joints into a V-section, 3 3/4" high with 4" side flanges. Make V with a 1/8" radius bend and turn up the edge of each flange 1/4". Make each unit in 8'-0" or 10'-0" lengths. Install continuously from top of footing to top of wall. Lap each joint 4" in direction of flow with flanges built into masonry. Solder joints below grade.

c. Floors: Bend expansion joints to form an inverted V-shaped water stop not less than 2 1/2" high with 4" side flanges having a 1/2" lip. Lap and solder joints.

COMMENT: See pages 38 and 39.

11. FLAT SEAM ROOFING

a. Size: Use 20 ounce rectangular sheet (16" x 18" or 18" x 24") for flat seam roofing. Notch corners and fold over pretinned edges 3/4".

b. Installation: Lay sheets over roofing felt specified in Paragraph 8. with long dimension parallel to eaves with cross joints staggered. Fasten sheets with cleats. Place cleats on the long side at the center of each sheet and adjacent to the intersections of the cross seams. On cross seams place two cleats per seam.

COMMENT: Omit rosin sized paper.

Bond with felt is not a problem since flat seam roofing is predicated on restriction of movement. See page 40 for details.

c. Soldering: Lock cleats into seams; flatten smooth in direction of flow. Sweat seams thoroughly with solder, producing watertight joints.

d. Edge Strips: At eaves and gable ends, terminate roofing by hooking it over a previously installed edge strip.

12. STANDING SEAM ROOFING

COMMENT: See page 41 for details.

Do not cleat cross seams.

a. Size: Standing seam roofing shall consist of (16 ounce sheets, 20" wide by 96" or 120" long with standing seams 16 3/4" on centers), (20 ounce sheets 24" wide by 96" or 120" long with standing seams 20 3/4" on centers). No straight run of standing seam shall exceed 30'-0", unless expansion cleats or intermediate expansion joints are provided.

COMMENT: Select 16 ounce copper for seams 16 3/4" on centers. Use 20 ounce for seams 20 3/4" on centers.

b. Surface Preparation: Place roofing felt and building paper over roof surfaces as specified in Paragraph 8.

c. Pan Method: Fold lower end of each pan under 3/4". Slit fold 1" away from corner to form a tab where pan turns up to make a standing seam. Fold upper end of each pan over 2". Hook 3/4" fold on lower end of upper pan into the 2" fold on upper end of underlying pan.

d. Roll Method: (Optional) Join short ends of sheets together with 1/2" wide double lock seams to form a strip (20") (24") wide by a length equal to the length of the roof slope.

COMMENT: The roll method may be used; however, it is more costly because of field labor. On slopes 3" to 6", a 1 1/2" wide locking strip may be soldered 4" below top folded edge. The fold on lower end of pan hooks onto locking strip.

e. Layout: Apply sheet metal roofing beginning at eaves with half-length sheets, staggering transverse seams. Space cleats 12" on centers in each standing seam. Loose lock roofing pans to valley flashing and edge strips at eaves and gable rakes.

f. Seam Forming: Standing seams shall finish 1" high except on curved surfaces where they shall finish 1/2" high. Bend up

one side edge 1½" and the other 1¾". The first fold shall be a single fold ¼" wide and the second fold shall be ½" wide. The locked portion of the standing seam shall be 5 plies in thickness. Fold lower ends of standing seams at eaves over at an angle of about 45 degrees. Terminate standing seams at ridge and hips by turning down in a tapered fold.

g. Ridges and Hips: Ridges and hips shall be provided with standing seams constructed as specified for standing seams of main roof.

h. Valleys: Form valleys of 20 ounce copper not exceeding 10'-0" in length. Lap joints 6" in the direction of flow. Extend valley sheet under roofing sheets not less than 6". At valley line, double fold valley and roofing sheets and fasten with cleats spaced 12", on centers.

13. BATTEN SEAM ROOFING

COMMENT: See page 42 for details.

a. Battens: Wood battens and their installation are specified under the Carpentry Section. Before installation of battens, install roofing felt and building paper in accordance with Paragraph 8.

COMMENT: Wood battens should be specified to be furnished and installed under the Carpentry Section.

b. Size: Batten seam roofing shall consist of (16 ounce sheets) (20 ounce sheets), 96" or 120" long. Turn up sides of sheets to top of batten plus ½" additional which shall then be turned at right angles to batten.

COMMENT: 16 ounce sheets are used for pans not exceeding 20" wide; 20 ounce sheets for pans not exceeding 26" wide.

c. Cross Seams: Form cross seams with a ¾" fold (under) on the lower end and a 2" fold (over) on upper end. Slit folds in cross seams at each corner, 1" in from batten to form a tab. Hook ¾" fold on lower end of pan into 2" fold on upper end of underlying pan.

d. Layout: Apply sheet metal roofing beginning at eaves with half-length sheets, staggering transverse seams. Space cleats 12" on centers, nailed to vertical face of battens.

e. Batten and Covers: Place cover strips over battens, locking edges with flanges of

pan malleted down against sides of battens. Cover batten ends with a cap folded and locked into extensions of batten covers and vertical legs of pans.

f. Ridges and Hips: Ridges and hips shall be copper covered battens similar to roof battens. At intersection of roof slope with ridge or hip battens, edges of roof pans shall turn up against ridge or hip battens, and terminate in a ½" horizontal flange at top of battens. Install cover strips over top of hip and ridge battens, constructed as specified for main roof.

g. Valleys: Form valleys of 20 ounce copper not exceeding 10'-0" in length. Lap joints 6" in direction of flow. Extend valley sheet under roofing sheets not less than 6". At valley line, flat lock valley and roof sheets.

h. Eaves: At eaves with no gutters, hook pan over a 24 ounce copper edge strip. Extend edge strip up under copper roofing 4" and secure with copper nails 4" on centers, 1" from upper end. At eaves with gutters, loose lock end of roofing pans into gutters.

i. Gables: Install a batten flush with gable end unless otherwise shown. Extend batten cover down exterior face and lock into edge strip.

14. BUILT-IN BOX GUTTERS

COMMENT: See page 44 for details.

a. Surface Preparation: Before installation of built-in box gutters, install roofing felt and building paper as specified in Paragraph 8.

b. Size: Form gutter linings with _____ ounce copper sheets conforming to profile of gutters. (Use 36" long sheets if sectional profile of gutter exceeds 36".) (Use 96" or 120" long sheets if sectional profile is less than 36".) Longitudinal joints will not be permitted. (Ends of 16 and 20 ounce sheets shall have ¾" locked and

soldered cross seams.) (Ends of sheets 24 ounces and heavier shall be joined by 1½" lapped, riveted and soldered cross seams.) (Copper rivets, 3/16" diameter, shall be spaced 3" on centers, in two staggered rows, ½" in from ends of lapped sheets.)

COMMENT: Insert weight of copper sheet based on criteria on page 5. Check sectional profile for size. Use rivets for sheets 24 ounces and heavier.

c. Fastenings: (Gutter linings having flat sections between 18" and 24" shall be secured with brass screws covered with 16 ounce copper caps soldered to lining, and spaced 48" apart along the center of the lining.) (When flat sections exceed 24", secure gutter linings with brass screws spaced not over 18" apart transversely and 48" apart longitudinally.) Screws shall be No. 12 x 7/8" round head. Use expansion shields for screws in stone. Provide brass washers, 1/16" thick by 1¼" in diameter under screw heads. Provide ¾" slotted holes in gutter lining to receive screws.

COMMENT: Check section profiles for fastener requirements.

d. Roof Edges

1. At Copper Roofing: Extend gutter lining under copper roofing not less than 6" and terminate in a ¾" folded edge secured by copper cleats spaced 12" on centers. Solder a continuous copper lock strip to lining at lower end of roofing. Hook lower end of roofing into lock strip to form a ¾" wide loose-lock seam.

2. At Shingle and Tile Roofing: Extend gutter lining under shingles and tile roofing not less than 6" and terminate in a ¾" folded edge secured by copper cleats spaced 12" on centers.

COMMENT: Use appropriate subparagraph.

e. Outer Edges

1. Stone and Masonry: Hook outer edge of lining over edge strip in a reglet in masonry filled flush with sealant.

2. Wood Cornice: Fold outer edge of lining ¾" and hook over edge strip.

COMMENT: Use appropriate subparagraph.

f. Expansion Joints: Provide midway between outlet tubes unless otherwise shown on drawings, at exterior corners, and where ends of gutter abut masonry walls. Close ends of each gutter section with copper of same thickness as gutter lining and flange, rivet and solder to gutter lining. The top edge of gutter ends shall have a horizontal flange 1½" wide for connection to expansion joint cover strip. The expansion joint shall have an open space 1" wide between adjacent gutter ends or ½" between a gutter end and adjacent wall. At gutter ends, provide a cover strip formed of 16 ounce copper over expansion joint and loose lock into horizontal flanges at top of gutter ends. Loose-lock joints shall provide for movement of gutter lining of ½" in either direction. Where ends of gutter abut a masonry wall, extend cover strip under a counter flashing built into the masonry. Terminate ends of cover strips in a manner to provide watertight connections and to permit freedom of movement of gutter lining.

COMMENT: See page 7 for location of expansion joints.

g. Outlet Tubes to Conductors: Make of copper tube or copper or red brass S.P.S. pipe. Braze to upper end of outlet tube a 2" wide flange ring of 32 ounce copper riveted and soldered to gutter lining. Space rivets not more than 3" on centers. Rivets shall be 3/16" diameter with copper burrs under the peened heads. Extend tubes at least 3" into leaders or downspouts.

h. Strainers: Provide removable basket type strainer in outlet tubes formed of No. 14 B & S gauge copper or brass.

15. HUNG MOLDED GUTTERS

COMMENT: See page 44 for details.

a. Size: Form hung molded gutters of the cross sectional profile shown of 20 ounce copper sheets 8'-0" or 10'-0" long. Lap ends 1" in direction of flow and solder and rivet seams. Rivets, 3/16" in diameter, shall be spaced 2" on centers.

b. Outer Edges: Reinforce outer edge with a ¾" x 3/16" brass stiffening bar. Extend roof edge 6" up under roofing and attach by cleats on 12" centers.

c. Expansion Joints: Locate expansion joints midway between outlet tubes and not over 30'-0" apart. Loose lock expansion joints and fill with sealant to allow ½" movement.

d. Braces: Form transverse gutter braces of 20 ounce copper, bent to form a channel 1½" wide with ¾" legs. Attach braces by riveting and soldering to top edges of gutter and space 36" on centers.

e. Hangers: Support gutter with ¾" x 3/16" brass bars riveted or bolted to outer edge, spaced 36" on centers, and extending up 6" under roofing. Secure straps with two brass screws at roof.

f. Outlet Tubes: Outlet tubes shall be riveted and soldered to gutters and shall extend 3" into leaders or downspouts.

g. Strainers: Provide removable basket type strainer in outlet tubes formed of No. 14 B & S gauge copper or brass.

16. LEADERS

COMMENT: Leaders may also be referred to as conductors and downspouts.

a. Size: Form leaders to size and shape shown in 8'-0" to 10'-0" sections. Longitudinal joints shall be locked. End joints shall telescope 1½".

b. Hangers: Support leaders in position clear of the wall by 1/8" x 3" red brass or copper straps spaced as shown on the drawings, but in no case more than ten feet. Prongs ½" high by ¾" long shall be punched from the strap to hold leader ¾" from wall, or a red brass rod ¼" diameter shall extend through the strap back of the leader. Extend straps on wall surface 2" on each side of leader and secure to masonry with bronze expansion shields and bronze machine bolts of the cinch bolt type. Attachment to wood shall be with bronze lag screws. Provide a shoulder of solder on each side of leader above each strap to carry weight of leader.

c. Elbows: Provide elbows at bottom where leaders empty onto splash blocks. Fit leaders into cast iron boots or drain pipes where shown and calk or cement joints.

d. Leader Heads: Form leader heads of 20 ounce copper of design and size shown. Lock and solder all seams.

17. GRAVEL STOPS AND FASCIAS

COMMENT: See page 45 for details.

a. Size: Form gravel stops and fascias to sizes and profiles shown, using 20 ounce copper sheets 8'-0" or 10'-0" long. Extend inner flange onto roofing 4" and nail on 3" centers.

b. Edge Strip: Hook lower edge of gravel stop or fascia ¾" over a previously placed edge strip.

c. Fastening: Lap ends of sheets 3" and

set the roof leg in plastic roofing cement. Hold end joints on fascia together by a copper clip soldered to underside of one sheet.

d. Flashing: Cover roof flange with 2 plies of roofing felt embedded in roofing cement.

18. PITCH POCKETS

At built-up roofing where steel supports, guy wires, etc., penetrate same, provide pitch pockets using 20 ounce copper. Pockets may be round or rectangular finish 2" high above finished roof level. Form pocket with 2" wide flanges placed on top of roofing with flanges covered by 2 plies of roofing felt well mopped with bitumen. Fill pocket with bitumen and slope top to drain freely.

19. COPINGS

Use 16 ounce copper sheets 8'-0" or 10'-0" long joined by a ¾" locked and soldered seam. Provide expansion joints every 24'-0" to 30'-0" using a 1½" loose-lock joint filled with sealant.

Terminate outer edges (edge strips) (reglets) as shown.

20. CLEANING

Remove all flux, scraps and dirt immediately. Excess flux shall be neutralized with a 5 to 10% solution of washing soda, then drenched with clean water.

COMMENT: Excess flux may cause permanent discoloration and acid stains.

21. COLORING OF COPPER

COMMENT: For coloring and treatment of copper see page 54. For additional information consult the Copper Development Association or its member companies.

22. GUARANTEE

The contractor shall guarantee all workmanship and materials for a period of _____ years from the date of completion and acceptance of the work as provided for under the General Conditions, and at his own expense, make good all defects which may develop during the warranty period.

COMMENT: Insert the number of years (2), (3), or (5) required for guarantee.

This section is prepared for those design professionals who would like more technical information about the properties and handling of copper. It is divided into segments dealing with 1) Sealants, 2) Corrosion, 3) Lead-coated copper, 4) Mechanized roofing, and 5) Natural weathering and chemical coloring.

SEALANTS

Traditionally, in copper roofing where water-tight seams and joints are required, soldering is specified. Face soldering of copper components, especially when done with inadequate care can result in a certain degree of disfigurement of the copper work, particularly as the copper weathers to the natural green patina, since the exposed solder develops a characteristic dull gray-black color. One way to minimize this is to specify blind soldering, i.e., the soldering is done from the back or concealed side of the components. There are instances, however, where blind soldering is not practicable. Another approach utilizes face soldering with the stipulation that all excess solder be mechanically removed from the exposed copper surfaces.

Over the past 20 years, the use of sealants has burgeoned in the construction industry. Sealants have been evaluated as replacements for solder to achieve water-tight joints and seams in roofing and flashing applications where the sealing medium is not required to provide strength to the joint. Sealant filled seams have been used successfully for standing seam and batten seam roofing applications where roof slopes are less than three inches in 12 inches. Sealants should not be used in sheet copper joints primarily designed to accommodate thermal movement of the metal. Non-hardening, elastic roofing cement is more appropriate for these applications.

Performance

The selection of sealants by generic type, conformance to Federal specifications, or brand names will not necessarily assure

satisfactory performance. Certain sealants classified by each of these means have performed well while others have not. Actual testing may be required in order to identify satisfactory sealants for a given application.

In general terms, based on actual testing, butyl, polysulfide and polyurethane sealants appear to exhibit reasonable compatibility and satisfactory performance when employed for various sheet copper applications. The suitability of silicone sealants for use with copper varies widely between manufacturers. Silicone sealants should, therefore, only be used when specifically recommended by the manufacturer. Acrylic, neoprene and nitrile based sealants have been observed to actively corrode copper. The use of such sealants, therefore, is not recommended.

Sealants which exhibit good compatibility and performance in service with copper 110 and 122 also tend to exhibit the same degree of compatibility and satisfactory performance when used in conjunction with copper alloys 220 (commercial bronze) and 230 (red brass).

Surface Preparation

In order to assure good sealant adhesion to the copper, the surfaces involved should be free of dust, dirt, oil and grease. The copper need not be bright, however, since the tightly adherent, natural oxide film is not detrimental to sealant adhesion.

Oil and grease can be effectively removed from copper surfaces by solvent or solvent emulsion cleaning with hydrocarbon solvents. Where maximum cleanliness is required, such degreasing should be followed by chemical cleaning. The simplest form of chemical cleaning involves washing the copper surfaces with soap, trisodium phosphate or sodium metasilicate and hot water followed by a plain water rinse and a drying wipe with clean rags. Suitable proportioning of the trisodium phosphate or sodium metasilicate is four to eight ounces by weight per gallon of water.

In recent years, a number of proprietary

and non-proprietary solutions utilizing inhibited chemicals have been employed for the cleaning of copper and copper alloy surfaces. Among these inhibited chemical cleaners are a variety of newly developed formulations based on alkalis and soaps such as sodium tetraborate, disodium phosphate, sodium silicate and soap made from various vegetable and animal oils often with the addition of a wetting agent.

CORROSION RESISTANCE AND STAINING

The natural corrosion resistance of copper permits its use in a broad range of atmospheric environments from coastal to heavy industrial. Copper reacts with the atmosphere weathering first to a brown oxide surface and eventually to the familiar green copper patina. This weathering reaction proceeds most rapidly in and around large metropolitan areas where the combustion of sulfur-bearing fossil fuels generates sulfur dioxide which dissolves in atmospheric moisture and is oxidized by the air to form dilute sulfurous and sulfuric acids, (acid rain).

When these acids, born by fog, dew or light rain, settle on copper surfaces, they react with the copper to yield basic copper sulfate (patina); this compound is sparingly soluble and quite adherent. The characteristic patina thus acts as a protective film which inhibits further corrosion. Where the surface areas exposed are large—such as a copper roof—the total corrosive effect is slight, because the reaction is spread over a large area and the moisture loses its acidity upon reacting with the copper.

Preventing Line Corrosion

On the other hand, this acid moisture is not neutralized when it falls on non-copper roofing such as tile, slate, wood, asphalt or similar inert materials such as glass skylights. Consequently a few simple steps must be taken to insure that the run-off from such a large inert area does not concentrate on a relatively small area of copper such as a valley, gutter or skylight frame. Under severe exposure conditions

of this type, when adequate design precautions are not taken, fairly rapid corrosion of the copper can occur which affords no opportunity for the protective basic copper sulfate patina to form. Where inert roofing is involved, the risk of corrosion is most pronounced at the edge line of the shingles adjacent to open valleys flashed with copper and at the drip line of the shingles which overhang copper gutter linings. Since the pitting corrosion that occurs is aligned with the shingle edge, it is often referred to as "line corrosion." The chemical reaction is accelerated in valleys where the shingle edges rest directly on the copper flashing, since the retention of a moisture bead, due to capillarity, increases the duration of the attack.

Protection from line corrosion is achieved by raising the shingle edges slightly by means of a cant strip, in order to break capillarity, or by providing a replaceable reinforcing strip between the shingle line and the copper valley flashing.

Galvanic Corrosion

When contact between copper and dissimilar metals cannot be avoided, copper is infrequently corroded, but may significantly accelerate the corrosion of the other metals (particularly aluminum and zinc and, to a lesser extent, steel and iron), if steps are not taken to protect them. Where copper contacts aluminum, the contact surfaces should be painted with bituminous or zinc chromate primers in order to deter galvanic corrosion of the aluminum. Taping or gasketing with non-absorptive materials or sealants is also effective. Care should be taken to prevent the wash from copper surfaces onto adjacent, exposed aluminum surfaces, since the traces of copper salts carried in the wash can accelerate corrosion of the aluminum.

Often, all that is required to separate copper and ferrous metals is a good primer of red lead, zinc chromate or bituminous paint. Where exposure is severe, lead or similar gasketing materials should be used. Lead should not be used, however, to separate copper and aluminum, since the resulting corrosion may be more severe than when copper and aluminum are in direct contact.

Staining

No copper project is complete until the necessary steps are taken to guard against staining of adjacent materials. A ½-inch drip edge is seldom adequate to protect against staining. A ¾-inch drip

edge provides the minimum acceptable width. Even a one-inch or 1 ¼-inch drip edge may be needed to handle some situations. Coating the surface of the light colored masonry with a clear, silicone, masonry sealant also aids in minimizing staining, since the sealant prevents absorption of the copper salt laden moisture. The use of lead-coated copper does not solve the problem. It merely substitutes a gray or black stain for the characteristic green one.

Moisture deposited by mists, dew or condensation on copper surfaces tends to pick up minute quantities of copper salts. If this copper laden moisture bleeds directly onto porous, light colored masonry (particularly marble and limestone), it is absorbed. When the moisture evaporates, the slight residue of copper salts redeposit to form the characteristic green stain. The condition does not occur with heavy rains or similar rapid runoff, since the dwell time of the moisture on the copper is short and little copper salt is picked up by the runoff. Staining results from the slow bleeding action of copper laden moisture. The problem can usually be avoided by providing generous drip edges to carry the moisture clear of the masonry.

LEAD-COATED COPPER

Lead-coated copper is copper in sheet or strip form coated either on both sides or on one side with lead. The lead coating is applied to the copper by either hot dipping the sheet or strip in a bath of molten lead or by electro-deposition in a plating bath.

Coating Weights

ASTM Standard B 101 recognizes two weights of lead coating: Class A Standard 12 to 15 pounds, and Class B Heavy 20 to 30 pounds. The weights specified are per hundred square feet of coated surface applied to both sides of the copper sheet or strip. For a Class A Standard coating, therefore, the weight of lead per side is from 6 to 7½ pounds per hundred square feet. In terms of thickness, this averages out to from 0.002 to 0.003-inches.

As one might expect, lead coating applied by the hot dip process exhibits a rougher, less uniform, appearance with greater variations in coating thickness than does electrolytic lead coating.

Lead-coated copper was developed and gained widespread use between the turn of the century and World War I. Its development was spurred by two principal desires: to provide a metal for roofing and flashing with the appearance and corrosion

resistance of lead at a lower cost and with significantly less dead weight; and to provide a roofing and flashing material whose runoff stains would be compatible with white painted woodwork and light colored masonry, particularly the more porous materials including marble, limestone, mortar and concrete. Lead-coated copper fulfills the first objective and very nearly satisfies the second. The stains produced range from light to dark gray in color and resemble the natural atmospheric weathering of the masonry or paint.

Gauge Selection

Lead-coated copper is suitable for a broad range of roofing and flashing applications. The strength and stiffness of the material are supplied by the copper. In general, therefore, the same ounce weights are specified. Normally, cold rolled temper copper is employed for lead coating. Recognizing that the hot dip process of lead coating may remove some of the temper previously imparted to the sheet or strip by cold working, some specifiers call for lead-coated copper one ounce weight heavier than for plain, cold rolled copper. For example, if 16 ounce cold rolled copper is deemed adequate for a particular flashing application, the specifier may utilize 20 ounce lead-coated copper in recognition of the slight loss of temper induced during the lead coating process.

The ease of forming of lead-coated copper is quite good, since the lead coating acts as a lubricant. Stamping and embossing of bas-reliefs and decorative ornament are more easily executed and produce finer detail when lead-coated copper rather than plain cold rolled copper is employed.

Soldering

Lead-coated copper solders readily. In order to assure sound joints of good strength, excessive fluxing, particularly when using fluxes of the zinc-chloride type should be avoided. During soldering, the lead coating tends to diffuse into the solder layer. If common 50-50, tin-lead, bar solder is used, this tends to produce lead rich joints of lower than normal strength. In order to counter the potential strength reduction of the joints, it is desirable to specify the use of a tin rich solder. A 60-40, tin-lead solder is satisfactory.

Recognizing that the lead coating on sheet and strip copper is quite soft and relatively thin, reasonable care should be exercised during fabrication and installation in order to avoid cuts and scratches which expose the copper. When the cop-

per is exposed, under exterior conditions, accelerated corrosion of the copper occurs by galvanic means. Similarly, rapid pitting corrosion due to galvanic action can occur in instances where the lead coating is porous or incomplete.

Lead-coated copper takes paint readily and holds it well. In fact, the durability of properly applied paint is usually enhanced by the lead coating, provided that the paint selected is suitable for the purpose. When permitted to weather naturally, lead-coated copper gradually darkens to a soft gray color. Because of lead's inherent corrosion resistance, chemical coloring to speed the dulling produced through natural oxidation is not deemed practicable.

Although copper of any gauge and temper can be lead-coated, for roofing and flashing applications, lead-coated copper is generally stocked in nominal 16 and 20 ounce weights of cold rolled temper; in sheets 24, 30 and 36-inches wide by 96 or 120-inches long.

MECHANIZED COPPER ROOFING

Practical power tools are available today for forming the pans and closing the seams of copper roofs. Through the years, the fabrication and installation of standing seam and batten seam copper roofing has involved labor intensive techniques of a high order. In their earliest forms, the bulk of the work was done on site, on the roof. In some instances, sheets or blanks of copper as small as two-feet by four-feet were lifted to the roof where the required bends for the longitudinal standing and batten seams, as well as the transverse clinch-lock seams, were formed in place using hand tools. In later years, speed of installation was increased through the utilization of rolls or coils of copper which were hoisted to the roof, and unrolled in place. A continuous run might extend from eave to ridge. Again, the bends for longitudinal seams and any transverse seams employed were formed by hand in place. The interlocking of the seams and their final closure was also accomplished utilizing hand tools.

Shop Fabrication

Subsequently, further increases in productivity were achieved by fabricating roofing pans in the sheet metal shop. Punch presses were employed to clip the corners of sheets, while the required bends for longitudinal seams were formed, first on hand operated bending brakes and later using power or press brakes. Bends for transverse seams were usually hand formed in the shop utilizing simple bench

mounted bending jigs. The use of bending brakes in the shop generally resulted in the production of roofing pans eight to ten feet long; a limitation imposed by either the length of the brake or the companion shear used to cut the sheets to proper width. The eight and ten foot lengths proved easy to handle in the shop, to transport to the construction site and to install on the roof, particularly where steep roof slopes were encountered.

History

Immediately following World War II, there were a number of isolated efforts to further improve productivity by forming long continuous pan lengths from coil stock. The equipment was generally located at the construction site, either on the ground immediately adjacent to the building or, in some instances, on flat portions of the roof itself. The copper roof on the Kiel Auditorium in St. Louis was installed with the aid of a mechanized pan forming machine. In the main, the closing and final dressing of seams was still accomplished using hand tools.

In the late 1950s, word reached the United States of the development, in West Germany, of companion, motor-driven, pan forming and seam closing machines for metal roofing.

In the early 1960s, a set of machines was exported to the U.S. for use in the installation of 20-ounce, lead-coated copper, standing seam roofing on three new dormitories at Amherst College, Amherst, Massachusetts. Although the use of the pan forming and seam closing equipment provided significant cost savings for the roofing contractor (estimated at roughly 20 to 25% of the total bid price) this early equipment exhibited a number of drawbacks which tended to mitigate against widespread acceptance.

One distinct disadvantage was weight. The pan forming machine, although billed as "portable," weighed almost 1,000 pounds. For the Amherst installations, the pan former was trucked to the construction site, then hoisted by crane to a specially prepared level work platform on the roof slope. Additional disadvantages of the pan former include the need for 220 volt electrical service to operate it, plus its limited flexibility in terms of pan widths and metal gauges. As designed, it was intended to produce only a single pan width from 27-inch wide coil stock. The gauge adjustment was also quite narrow. All of these factors combined to limit acceptance. Several of these pan formers

are still in use in the United States.

Through periodic modification, adjustment capabilities were provided in terms of pan width and metal gauge.

The companion seam closing machine also had shortcomings. Again, weight was one. This unit weighed 83 pounds which made it difficult for one man to handle, even on moderate slopes, and almost impossible for two men to handle, without a belaying rope, on steep slopes. It too was powered by a 220 volt motor. The seam closer was specifically designed for standing seams and can only handle a single seam height.

Current Equipment

Today, there are more than half a dozen power seamers marketed by various manufacturers. In the main, they are far more versatile than the earlier equipment. Most work off standard 110 volt power. In addition, all of the units are much lighter in weight and those with the motor mounted directly over the forming rolls provide excellent stability even on steep roof slopes. The versatility of some models has been enhanced through the provision of spring loaded rolls so that the rolls adjust to varying seam thicknesses. Both standing seam and batten seam closing equipment are available.

A recently introduced power pan former for metal standing seam roofing is also considered superior to its earlier counterpart. The weight of the unit is 440 pounds, which makes it more portable. The unit operates off standard 110 to 125 volt current at a forming speed 50 percent greater than the earlier pan former. The unit is adjustable to handle coil widths of 12 to 27½-inches which yields pans with one-inch high standing seams from 9 to 24½-inches wide. A machine for the production of batten seam roofing pans is not yet available.

Advantages

Probably the greatest advantage of the power pan forming equipment is the ability to produce roofing pans in continuous lengths limited only by the roofing contractor's ability to transport to the job site and handle without damage during installation. In fact, the pan former can be set up at the job site to pay off the formed pans directly onto the roof slope. The ability to produce long pans minimizes the need for transverse joints and thus the potential leakage problem associated with such joints when metal roofing is installed on minimum slopes. Continuous runs in

54 excess of 40 feet have been installed.

When a single pan length exceeds 30 feet, the use of expansion cleats is required in order to effectively cope with anticipated thermal movement of the pans. For runs in excess of 30 feet, standard cleats should be positioned at the midpoint of the pan length to provide anchorage, with expansion cleats installed at the standard spacing of 12-inches on centers from the point of anchorage to the ends of the pan. No other special precautions are required.

Limited installation trials, utilizing a power pan former and power seamer for half of an 8,000 square feet roofing installation, and conventional fabrication and installation methods for the other half of the roof, indicate that the power equipment produces significant labor savings. For example, on the roof in question, shop fabrication was reduced approximately 60 percent, while field fabrication and installation were completed with at least 20 percent fewer man hours. In addition, the roofing formed and installed using the power equipment required approximately 5 percent less square footage of material. On the basis of these documented savings, it appears possible to amortize the equipment costs on a single installation with a total roof area in excess of 10,000 square feet. Use of the power equipment is most favorable when employed on large, relatively uncomplicated (unbroken) roof surfaces.

NATURAL WEATHERING AND CHEMICAL COLORING

The natural weathering of copper to the characteristic blue-green or gray-green patina is a direct consequence of the mild corrosive attack of airborne sulfur compounds—principally stemming from the combustion of fossil fuels. In the atmosphere, these compounds combine with water vapor to form dilute oxidizing acids which react with copper surfaces.

As natural weathering proceeds, the metal exposed to the atmosphere changes in hue from the natural salmon pink color through a series of russet brown shades to light and dark chocolate browns and finally to a dark, dull slate gray or sooty black from which the ultimate blue-green or gray-green patinas spring. The initial transition from the natural salmon pink color to the russet browns stems from the formation of copper oxide conversion films on the exposed metal surface.

During the initial weeks of exposure,

particularly in humid atmospheres or in areas of frequent rainfall, radical color changes often take place with iridescent pinks, oranges and reds interspersed with brassy yellows, blues, greens and purples observed. These sometimes shocking color variations result from the initial formation of the oxide surface films which are so thin that rainbow-hued interference colors are seen. As the natural oxide film builds in thickness during continued exposure, the interference colors fade and are replaced by relatively uniform russet brown shades.

As weathering progresses, cuprous and cupric sulfide conversion films are interspersed with the initial oxide film. These sulfide conversion films range from chocolate brown to black. As they build, the exposed metal surface darkens appreciably. Continued weathering results in the conversion of the sulfide films to the basic copper sulfate patina.

In industrial and seacoast atmospheres, the natural patina generally forms in from five to seven years. In rural atmospheres, where the quantity of air-borne sulfur dioxide is relatively low, patina formation may not reach a dominant stage for from ten to 14 years. In arid environments, the basic sulfate patina may never form due to the lack of sufficient moisture to carry the chemical conversion process to completion. Similarly, exposed horizontal surfaces develop the patina more rapidly than sloping surfaces which, in turn, patinate more rapidly than vertical surfaces. The critical variable, in all instances, is the dwell time of moisture on the exposed surfaces.

The progressive oxide, sulfide and sulfate films which develop on copper exposed to the atmosphere are quite thin—two to three thousandths of an inch—highly adherent, but with relatively low abrasion resistance. Neither the oxide nor sulfide films are particularly corrosion resistant. The sulfate patina, on the other hand, is highly resistant to all forms of atmospheric corrosion, once it has had an opportunity to form completely. It thus significantly increases the durability and, hence, the service life of copper roofing and flashing. The natural weathering cycle of copper is illustrated by the 12 sequential color plates on the inside back cover.

Although, as stated above, the natural weathering of copper to the ultimate sulfate patina yields the most durable installation, frequently, architects and/or building owners express the desire either

to inhibit natural patina formation, in an effort to preserve the uniform russet brown or chocolate brown shades of the oxide and sulfide conversion films, or to hasten the patina formation through chemical means. There are potential drawbacks associated with both of these approaches which the architect or owner should be aware of before opting to proceed.

In architectural parlance, the natural forming or chemically induced oxide and sulfide conversion films on the surface of copper or its alloys are referred to as "statuary" or "oxidized" finishes. In color, they range from light russet brown to ebony. Chemical coloring of exposed flashings, chimney caps and similar small surface areas has been undertaken from time to time with reasonable success.

Because of the nature of the reaction of the coloring solutions with the metal surface, application to large surface areas such as roofs, spires and domes is deemed impractical, since color uniformity is difficult to control and the hand application methods employed are expensive. Where large areas are involved, therefore, natural weathering to the desired shade is encouraged, at which point, further color change can be retarded through the application of oil or wax to the weathered copper surface.

Except in arid climates, copper usually weathers to a uniform russet brown within six to 12 months of initial exposure to the atmosphere. In arid climates, due to the absence of moisture, the weathering process is significantly slowed. It may require several years of exposure for the copper to achieve the desired shade. In addition, the multi-hued interference colors, previously mentioned, may persist for months rather than days or weeks.

At times there is concern with regard to color variations during or immediately following installation of large expanses of copper roofing or flashing. Such color variations are common and usually transient tending finally to disappear as natural weathering proceeds. There are two principal sources for such color variations. One involves the storage conditions from the time of manufacture until the time of installation, while the second involves exposure conditions following installation. For both conditions, time is an important variable. Moisture is also a key factor.

Once a copper sheet is sheared to size in the mill, it is usually packed in wood cases with a lining of moisture resistant

kraft paper. When stored in a heated mill or warehouse, oxidation (the principal cause of color change) proceeds at a slow rate, since the environment is relatively dry and the copper surface is usually still coated with a thin film of rolling oil.

The first significant oxidation of the metal may occur when it is shipped. In transfer, the cases may be exposed to rain, snow or high humidity conditions on open loading docks. Temperature changes can cause condensation within the paper wrappings inside the case. With moisture present on the metal surfaces, oxidation accelerates. Lengthy storage in unheated premises can, and often does, produce similar results.

Once received by the installing contractor, the metal may be subject to storage conditions which promote continuing slow oxidation. Fabricated goods may be further exposed to the weather during shipment to and storage at the construction site prior to installation. When installed, oxidation is continuous, but the rate fluctuates depending on the amount and duration of moisture present, temperature changes, contaminants in the air, the sunshine and even wind velocity.

Since installation of large expanses of copper roofing may take weeks or even months depending upon weather conditions and working conditions, color variations can and frequently do result from differing lengths of exposure and climatic changes. Natural weathering eventually produces uniform appearance in every case.

Oiling and Waxing

The primary purpose in oiling or waxing is to provide a barrier layer which excludes moisture from the copper surface and, hence, prevents the chemical conversion reactions from proceeding. Since oils and waxes tend to degrade and dissipate when exposed to the weather, reapplication at periodic intervals is required in order to successfully inhibit the natural weathering process. For roofing and flashing work, oiling predominates. Waxing is generally reserved for architectural components subject to close inspection and/or traffic. The oils are usually applied to the metal surface with the aid of a clean cloth, swabs or mops. The oil must be applied sparingly, otherwise the resulting tacky surface tends to attract and hold accumulated dust and dirt which detracts significantly from the desired appearance of the roofing or flashing.

The choice of oils is critical. Linseed oil,

both boiled and raw, has been widely specified for such purposes in the past. The use of this oil is still frequently referenced in the literature. Despite past acceptance, the suitability of the oil is open to question. Boiled linseed oil contains a small amount of varnish. When applied to copper surfaces exposed to the atmosphere, the varnish dries or sets producing a thin, hard, impermeable film. Since the film excludes moisture, it is desirable in this respect. Unfortunately, upon prolonged exposure to the elements, the film degrades. As it breaks down, it yellows badly which alters the appearance of the copper surface. More important, it sluffs off the copper surface unevenly. As a result, some areas of the copper are exposed and begin again to weather, while other portions continue to be protected by the varnish film. This ultimately results in a badly mottled or variegated surface coloration.

Raw linseed oil contains no varnish or driers. It remains tacky for an extended period of time following application. Failure to remove excess oil results in the accumulation of dust, dirt and debris over the copper surface. In addition, excess oil remaining in contact with the copper for any length of time reacts with the copper to produce insoluble organic copper salts which are characteristically dark green in color. The formation of these salts defeats the basic purpose of oiling; that is, to retard natural patina formation.

Crude oil has been used in the past with some degree of success. When applied with a heavy hand, it tends to be a dirt catcher. In recent years, evaluation of various oils has led to the tentative conclusion that, as a group, high grade paraffin oils, which are light-bodied petroleum distillates are best. They are readily available, easy to apply, provide a reasonable degree of protection, and, when applied sparingly, are less likely to accumulate dust and dirt. One potential drawback associated with the paraffin oils is the fact that, since they do contain paraffin wax, the wax is deposited on the metal surface. Frequent and/or heavy applications tend to produce a build-up of wax on the metal which alters the color of the surface and produces streaking.

Where oiling is employed on copper roofing or flashing installations, reapplication as infrequently as once every three years can effectively retard patina formation. In arid climates, the maximum time span between oilings may be extended to

from three to five years.

Chemical Coloring

Because of the time required for copper to weather to the ultimate blue-green or gray-green patina, men have sought for centuries to hasten the process by chemical means.

As far back as 1928, the literature documented at least 26 processes for developing an artificial patina on copper. Tests conducted at the time failed to reveal a single formula capable of producing consistently satisfactory results. Although the number of formulas published continues to grow, the consistent reproduction of a satisfactory patina in terms of appearance and durability by chemical means continues to prove an elusive goal.

The majority of the formulas extant depend upon the action of various chloride salts to achieve the desired end result. A few employ sulfate-chloride or chloride-carbonate combinations. Principal problems encountered are lack of adherence and color instability. This is not surprising, since the basic chloride salts of copper are not only fairly soluble, but photosensitive as well. Perhaps, the prime reason for the popularity of the chloride formulas is the fact that color develops almost immediately following application.

The chemical formulations for three processes which have found repeated use for chemically inducing a patina are listed below. Two utilize chloride salts and the third is a sulfate solution.

AMMONIUM CHLORIDE

Dissolve sufficient ammonium chloride crystals (commercial sal ammoniac) in water to form a saturated solution.

CUPROUS CHLORIDE-HYDROCHLORIC ACID

Dissolve the following in 500 ml of warm water: cuprous chloride crystals ($Cu_2Cl_2 \cdot 2H_2O$) 164 grams, reagent hydrochloric acid 117 ml, glacial acetic acid 69 ml, ammonium chloride (NH_4Cl) 80 grams, arsenic trioxide (As_2O_3) 11 grams, when dissolution is complete, dilute to 1 liter (1,000 ml) with water.

AMMONIUM SULFATE

Dissolve in 1 liter of warm water: ammonium sulfate (technical grade) 111 grams, copper sulfate 3.5 grams, concentrated ammonia (sp. gr. 0.90) 1.6 ml.

The ammonium chloride formula was favored by Frank Lloyd Wright. It is applied by either brush or spray to a clean, bright, copper surface. Wright specified that the solution be mixed 24 hours prior to its use.

56 Two applications are required with a lapse of 48 hours between applications. 24 hours after the final application, the copper is sprayed with a cold water mist. Wright emphasized the fact that dry weather is required throughout the entire period.

Although this coloring method was used with apparent success on the Price Tower, Bartlesville, Oklahoma, it failed to last on the copper roof of a large residence in Dallas, Texas. After five years, the blue-green patina initially developed completely disappeared leaving the copper a light russet brown in color. The ammonium chloride solution tends to chalk and flake if applied too heavily and is also apt to dissipate in heavy rain. Both factors may have contributed to the failure previously described.

The cuprous chloride-hydrochloric acid solution, or modifications thereof, has been used in both Europe and Asia as well as in this country. It can be spray-applied or stippled on with a sponge. Because of its acid nature, suitable spray equipment may be difficult to procure. The solution is both acid and toxic. A distinct advantage of the process lies in the fact that it can be applied to either bright or weathered copper. If possible, the desired color should be attained in a single application. Reapplication—particularly in direct sunlight—may cause a reaction between the solution and the salts initially deposited, producing a smooth, hard, colorless film similar in appearance to varnish.

The ammonium sulfate process is designed specifically for spray application. The metal surface must be clean, dry and

relatively free from oxide film. As many as six to eight spray coatings are required to produce a color of suitable intensity. Unless the relative humidity is above 80% during the operation, proper color development will not occur. Chemical attack should continue for a minimum of six hours under high humidity conditions.

Because production of an artificial patina on copper is dependent upon a number of variables, including temperature, humidity, wind velocity, surface condition of the copper and method of application, wide variations in the results achieved have been experienced. Reliability of all present methods can, at best, be considered only fair to poor.

Clear Coatings

Infrequently, an architect or owner seeks to preserve the bright natural color and high reflectivity of copper roofing and flashing by protecting the exposed surfaces with a clear organic coating. The four and one-half acre domed copper roof on the Sports Palace in Mexico City, erected for the 1968 Olympics, was preserved in this manner using an air-drying acrylic lacquer known as "Incralac" which contains benzotriazole to inhibit underfilm corrosion.

For smaller areas long term protection can be achieved by applying a clear organic coating. Air-drying formulations are among the most convenient to use, and the Incralac formulation has proven to be most protective. In research initiated by the International Copper Research

Association (INCRA), Incralac provided the best protection of all air dry coatings tested. When applied to a properly cleaned metal surface, Incralac provides excellent protection outdoors, even in highly corrosive industrial and marine atmospheres.

The use of non-metallic abrasive pads (such as Scotch-Brite) followed by washing with a cleaning solvent, provides a surface for maximum performance. Steel wool should not be used because it sometimes contains a corrosive inhibitor which may cause discoloration later on. If Scotch-Brite is not available, the surface should be thoroughly washed with a solvent or alkali cleaning solution.

Incralac is designed for spray application. Conventional spray equipment can be used, applying first a mist coat, followed by a wet coat. Two coats are recommended with at least 30 minutes air dry between coats.

Naturally weathered copper roofing, however, remains the first choice of architects and building owners although clear coatings, chemical coloring processes, oils and waxes are available. The practical benefits of the durability of copper roofing as measured by centuries of service coupled with minimal maintenance are the primary reasons that copper remains the preferred material for quality roofing applications. Modern power tools and improved fabrication and installation techniques make copper roofing economically viable as well.

WEATHERING OF COPPER

This weathering cycle represents a copper roof at a 45° angle with a southern exposure in a typical northeastern industrial city.



UNEXPOSED



4 MONTHS



8 MONTHS



1 YEAR



2 YEARS



3 YEARS



4 YEARS



5 YEARS



7 YEARS



10 YEARS



15 YEARS



25-30 YEARS



COPPER DEVELOPMENT ASSOCIATION INC.
2 Greenwich Office Park, Greenwich, CT 06836
203-625-8210 FAX: 203-625-0174